

ASHTREE

VISION & SAFETY



**Designers and manufacturers of mirrors and mirror arms -
Suppliers of Warning and Safety Products**



Ashtree has been in business since 1977 and is now into a 6th decade in the industry. We started as an importer and distributor of commercial parts, but we evolved into a company that designs, develops and manufactures mirrors and mirror arms. Our wealth of experience has helped us to grow a global customer base and we provide visibility solutions for various applications and industries, such as construction, agriculture, materials handling, road transport, mining and more.



Looking to the future we are proud to introduce our new product, the AVS-VIS1000, a revolutionary camera system that meets the R46 regulation for European markets. The AVS-VIS1000 offers a full and clear view of the vehicle's surroundings, enhancing driver & passenger safety and comfort. Meeting class II & IV requirements, it can help reduce blind spots, lower fuel consumption and maintenance costs. Whether you need a camera system for a bus, a truck, a van, or any other commercial vehicle, the AVS-VIS1000 camera system is the perfect solution for you.

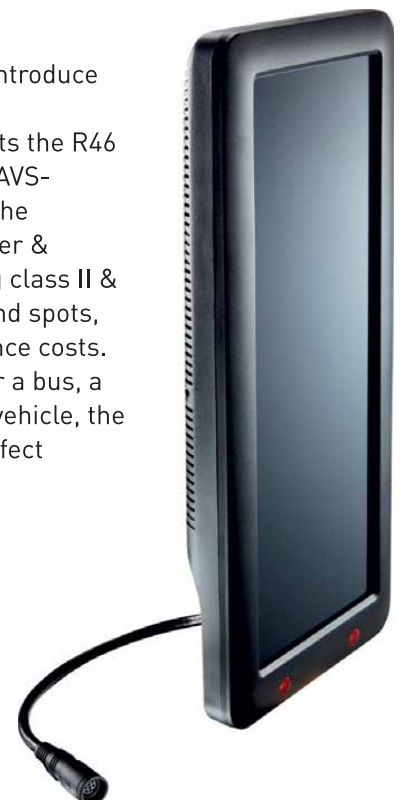

Contact us today to find out more about this innovative product and how it can benefit your business.

However, this doesn't mean we're abandoning our passion for mirrors. We have also developed new products such as the M930 twin lens mirror and other innovative projects such as our unique beacon mount solution that you can find in this catalogue.

We've also invested in new machinery, such as our automatic tube bender and a robotic welder. These have streamlined production, reduced lead times and helped keep costs down.



We have grown and adapted to the changing market since 1977. We are ready to face the new challenges that lie ahead. Ashtree is a company that always looks for innovation and improvement.

At Ashtree, we care about the environment and the effects of climate change. That's why we have taken several steps to reduce our carbon footprint and become a PAS 2060 certified, carbon neutral, organisation. We have:

- Installed a 100kWh solar power system on our factory roof.
- Added solar batteries to store excess energy for later use.
- Switched to 100% renewable electricity from the grid.
- Replaced our gas heating system with a cleaner alternative.

We are proud of our carbon reduction initiatives. If we all work together we can make a positive difference for our planet.



Certificate Number 21627



Certificate Number 21627



Part Number Index



Ashtree Part No.	Page No.	Ashtree Part No.	Page No.	Ashtree Part	Page No.	Ashtree Part No.	Page No.
AVS-1000CAM	6	M310CEB	11	MO225CE	10	S1360	42
AVS-1000MON	6	M310FE	11	MO613CE	15	S1361	42
AVS-2000CAM	7	M310FEA1	31	MO613CE-Black	15	S1370	42
AVS-2000MON	7	M310FEB	11	MX250CE	22	S1372	43
AVS-ABM202	55	M400CE	11	MX250CEB	22	S1374	43
AVS-ALARM100	53	M4101CE	11	MX430CE	22	S1375	43
AVS-ALARM200	53	M410CE	11	MX430CEB	22	S1376	43
AVS-ALARM300	53	M430CE	19	MX4402CE	23	S1377	43
AVS-ALARM400	53	M430CEA1	19	MX4402CEB	23	S1378	43
AVS-ALARM500	53	M430CEB	19	MX440CE	23	S1381	43
AVS-ALARM600	53	M435CE	20	MX440CEB	23	S1382	43
AVS-BAL1	53	M435CE	31	MX450CE	23	S1384	43
AVS-BEA200	51	M435CEA2	32	MX450CEB	23	S1385	44
AVS-BEA201	51	M435CE-Stud	20	MX550CE	21	S1390	44
AVS-BEA202	51	M435CE-Stud	31	MX550CE	23	S1397	44
AVS-BEA202-GRN	52	M4402CE	20	MX550CEA	21	S1413	37
AVS-BEA203	51	M4402CEB	20	MX550CEA3	21	S1500-46/54-YEL	45
AVS-BSALARM	53	M440CE	11	MX550CEB	21	S1500-64/44	45
AVS-BSWLED	53	M440CEB	11	MX550CEB	23	S1500-78/63	45
AVS-CCTV201	8	M450CE	12	MX555CE	24	S1550-16/45	45
AVS-CCTV300	8	M450CEB	12	MX555CEB	24	S1550-16/55	45
AVS-CCTVEXT10M	8	M455CE	20	MX5601CE	24	S1550-16/65	45
AVS-CCTVEXT15M	8	M455CEB	20	MX5601CE	36	S1550-28/52	45
AVS-CCTVEXT20M	8	M5000CE	12	MX6351CE	21	S1550-33/52	45
AVS-DIN101	52	M5000CEA4	12	MX6351CE	24	S1550-42/42	45
AVS-DIN102	52	M5000CE-S1801	13	MX6351CE	36	S1550-61/45	46
AVS-DIN103	52	M5000FE	12	MX635CE	21	S1550-66/37	46
AVS-DIN104	52	M500CE	12	MX635CE	24	S1550-73/69	46
AVS-DIN105	52	M500FE	12	MX635CE	36	S1550-76/45	46
AVS-DIN106	52	M504CE	20	MX640CEB	24	S1550-79/52	46
AVS-DIN107	52	M504CEA	20	MX725CEB	25	S1550-83/64	46
AVS-DIN108	52	M5201CE	13	MX941	35	S1550-85/70	46
AVS-FRE20/25	53	M520CE	13	MX941A	35	S1550-86/52	46
AVS-GBK1	52	M528CE	13	MX941B	35	S1551-16/50	46
AVS-GBK2	52	M545CE	13	MX942	36	S1601	47
AVS-MIRCAM	8	M545CEB	13	MX942A	36	S1602	47
AVS-MLB200	55	M555CE	13	MX942B	36	S1603	47
AVS-MLB500	55	M555CEB	13	MX943	25	S1604	47
AVS-MLB600	55	M5601CE	21	MX943	32	S1605	47
AVS-PNP1	53	M5601CE	33	MX943	36	S1750-16/50	48
AVS-SBLT100	52	M5601CE	35	MX943A2	32	S1750-16/55	48
AVS-SBLT105	52	M5601CEA	21	MX948	25	S1750-28/52	48
AVS-SCENE1	54	M5601CEA	33	MX948	37	S1750-61/45	48
AVS-SENSORSYS1	53	M5601CEA	35	MX948B	25	S1801	50
AVS-SIDCAM	8	M560C	33	MX948B	37	S1802	50
AVS-SLWLED4	54	M560C-42	35	MX950B	37	S1851	50
AVS-STDCAM	8	M600CE	14	MX950-STUD	37	S1852	50
AVS-TMA100	51	M600CESW	14	MX950-TUNNEL	37	S2001	49
AVS-TMA200	51	M600FE	14	MX951B	37	S2002	49
AVS-TMA300	51	M602CE	14	MX951-STUD	37	S2003L	49
AVS-TPD100	52	M6101CE	14	MX951-TUNNEL	37	S2003R	49
AVS-WIRELESS7Kit	9	M610CE	14	MX952	37	S900-DIN-Ver	51
AVS-WIRELESSCAM1	9	M613CE	14	PLH50	61	S900-DIN-Hor	51
AVS-WLCU990	54	M6261CE	15	PLH52	61	S901	39
AVS-WLMB2	54	M626CE	15	PLH60	61	S901-12	39
AVS-WLRE616	54	M631CA	32	PLH74D	61	S902	39
AVS-WLRE690	54	M631CA	32	PLH74S	61	S903	39
AVS-WLSQ4 Blue	55	M640CEB	15	PLH74T	61	S904	39
AVS-WTK1	54	M701CE	15	S1090	19	S905	39
G200FE - GW927CEH	56 - 59	M702CE	16	S1091	21	S907-L	39
MM2000CE	10	M703CE	16	S1173	33	S907-R	39
M2000CEA2	31	M7141CE	16	S1181-Y3135	55	S920	39
M2000FE	10	M714CE	16	S1186	40	Y2089	40
M2000FEA2	31	M714FE	16	S1187	40	Y2670-3	42
M200CE	10	M725CEB	16	S1190	40	Y2670-3	47
M200FE	10	M800CE	17	S1191	40	Y2670-4	42
M235C	31	M807CE	17	S1192	40	Y2670-4	47
M2381CE	19	M820CE	17	S1192S	40	Y2672	45
M238CE	19	M8231CE	17	S1193	41	Y2675	27
M245C	33	M912CEH	27	S1194	41	Y2677-12	27
M245C-42	35	M9151CEH	27	S1195	41	Y2677-24	27
M250CE	19	M915CEH	27	S1196	41	Y2678	28
M250CEB	19	M916CEH	27	S1198	41	Y2683	29
M3101CE	11	M922CEH	27	S1198S	41	Y3098	28
M3101CEB	11	M9231CEH	28	S1201	41	Y3098	29
M3102CE	19	M923CEH	28	S1216	20	Y3107	28
M3102CEA1	31	M925CEH	28	S1222	41	Y3107	29
M3102CEB	19	M926CE	28	S1230	33		
M310CE	10	M930CEH	29	S1350	42		
M310CEA1	31	M935CEH	29	S1352	42		

Contents

The Ashtree “E” numbers index can be found inside the back cover.

Camera Systems	PAGES 6 - 9
Main Mirrors - Classes II & III	PAGES 10 - 17
Wide Angle Mirrors - Classes IV, V & VI	PAGES 18 - 21
Unbreakable Mirrors	PAGES 22 - 25
Powered & Adjustable Mirrors	PAGES 26 - 29
Interior Mirrors	PAGES 30 - 33
Safety Mirrors	PAGES 34 - 37
Mirror Arms	PAGES 38 - 50
W.A.S.P. - Warning & Safety Products	PAGES 51 - 55
Mirror Glasses, Elements, Brackets & Accessories	PAGES 56 - 63

AVS-VIS1000, R46 approved, class II & IV CMS System

A truck and bus driver's rearward fields of visibility are covered by devices approved to class II & IV, please see illustration below. These are traditionally mirrors, but increasingly, cameras are being used more and more.

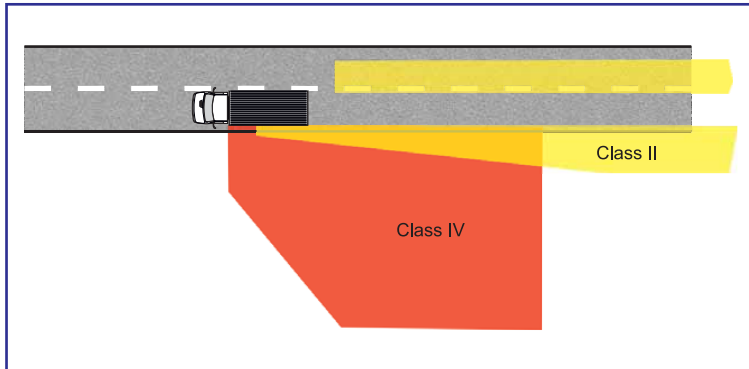

The Ashtree AVS-VIS 1000 CMS system has been class II & IV, R46, approved in Europe, for use on road going vehicles. With left and right hand side versions available these are suitable for use on many types of vehicle.

The low-profile camera pod will help reduce street furniture strikes and could help lower fuel consumption while the IP69K cameras are good for use in all weather conditions. In lower light the system will automatically switch to a night vision mode.

The 12.3", split screen HD monitor, will operate on power supplies ranging from 12v-36v.

For full technical specifications please contact Ashtree.



AVS-1000MON



We can supply a range of various mounting brackets, but the monitor was designed to be used with our unique clamp that will connect to 10-20mm diameter poles.



AVS-VIS2000, R46 approved, class V & VI CMS System

The class V & VI fields of visibility, please see image below, are particularly important when vehicles are in areas with people around or involved in low-speed manoeuvring. Vulnerable road users can be lost from sight if they are at the front, or close to the side, of a truck or bus. This system gives great visibility of the front, class VI or on the kerb side, class V.

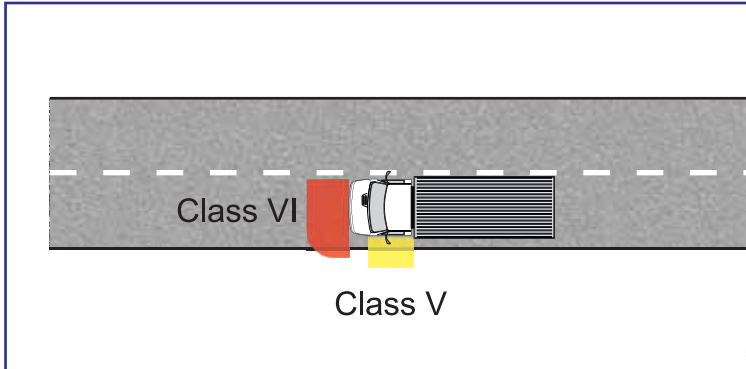

**Available
in 2024**

The monitor starts up in only two seconds. It operates from 12-32v, has a 7" screen, 180mm x 120mm and the LED backlit panel has 1024 x 600 pixel resolution.



AVS-2000CAM

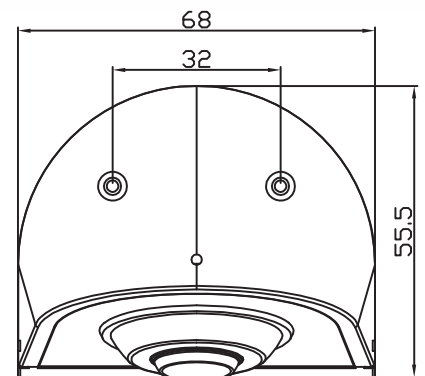
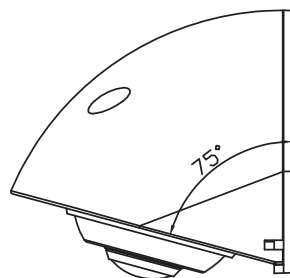

The camera is powered from the monitor and has an IP68 waterproof rating. The camera is angled to create the best possible viewing angle and mounts on two holes on the top of the housing.

For full technical specifications please contact Ashtree.

7.0" REVERSING CAMERA KIT



AVS-STDCAM

7 inch HD monitor

AVS-CCTV300

- 7 inch Full color HD monitor with audio
- 3 Camera inputs
- ECE R10 (E24) & UKCA approved
- IP68 rated camera, angle 110 degrees
- 18 Infrared LEDs Night Vision Camera
- 15m extension cable included
- Power supply DC 12-32V
- Display resolution 1024(H) x RGB x 600(V)
- Colour system NTSC/PAL

AVS-CCTVEXT10M AVS-CCTVEXT15M AVS-CCTVEXT20M

10m, 15m or 20m extension cable for mounting additional cameras



Accessories



AVS-CCTV201

CCTV Digital 10.1 inch monitor.



AVS-STDCAM

Standard camera, CMOS with microphone, angle 120 degrees. IP68K



AVS-MIRRCAM

Additional side camera - mirror arm mounted



AVS-SIDCAM

Additional side blind spot camera

7.0" WIFI REVERSING CAMERA KIT



7 inch wireless monitor

Take the hassle out of cabling with our 7inch wireless CCTV system*. The monitor is capable of supporting up to 4 cameras and has a built in DVR for continuous recording making this a very flexible option should you wish to upgrade at a later time.

AVS-WIRELESSCAM1

additional cameras available

AVS-WIRELESS7KIT

Wireless Monitor Specification:

- 7 inch wireless monitor with split screen and built in DVR (SD card not included)
- Transmitter distance 30-120m
- Full HD display with audio
- 4 camera capable
- 10-30v
- Includes 1 x monitor, 1 x camera

Wireless Camera Specification:

- 2.4GHz digital transmitter
- 120 degrees view angle
- Ip68
- With audio



AVS-WirelessCam1

*Monitor and camera require 10-30v power supply

Main Mirrors - Classes II & III



Computer rendered image of the new M703CE mirror - see page 16

Class II & III mirrors are the drivers main mirror on road going vehicles and are widely used on off highway machinery as well.

Ashtree manufactured products are widely used both by OEM's and also in the aftermarket.

Most mirrors in this section are available with universal clamps that fit arms of 10-20mm or 16-28mm in diameter. Other mounting options are available.

M200CE

e11 III 03*6624

Fitment	Radius
13-16mm	1200mm



M200FE

e11 III 03*6624

Fitment	Radius
13-16mm	Flat



M2000CE

e11 III 03*6624

Fitment	Radius
10-20mm	1200mm



M2000FE

e11 III 03*6624

Fitment	Radius
10-20mm	Flat



M0225CE

e4 II 02*5914

Fitment	Radius
20mm	1200mm



Main Mirrors - Classes II & III

M310CE

e11 III 03*6635

Fitment: 10-20mm | Radius: 1200mm | M310CE Yellow

Replacement Glass: G410CE



M3101CE

e11 III 03*6634

Fitment: 10-20mm | Radius: 1800mm

Replacement Glass: G4101CE

M310FE

e11 III 03*6635

Fitment: 10-20mm | Radius: Flat

Replacement Glass: G410FE

Heated version available, may be subject to minimum quantity

Spares Kit - Y2652 - see page 61

"B" versions of these mirrors available with clamps for 16-28mm mirror arms

M410CE

e11 III 03*6627

Fitment: 16-22mm | Radius: 1200mm

Replacement Glass: G410CE



M4101CE

e11 III 03*6628

Fitment: 16-22mm | Radius: 1800mm

Replacement Glass: G4101CE

Spares Kit - Y2652 - see page 61

M400CE

e11 III 02*1008

Fitment: 13-16mm | Radius: 1200mm

Replacement Glass: G400CE



M440CE

e11 II & III 03*6619

Fitment: 10-20mm | Radius: 1200mm | M440CE Yellow

Replacement Glass: G410CE | UNBREAKABLE MIRRORS



M440CEB

e11 II & III 03*6619

Fitment: 16-28mm | Radius: 1200mm | M440CEB Yellow

Replacement Glass: G410CE | UNBREAKABLE MIRRORS

Main Mirrors - Classes II & III

M450CE

II 46R 048749

Fitment: 10-20mm
 Radius: 1200mm
 Replacement Glass: G450CE
 UNBREAKABLE MIRRORS



M450CEB

II 46R 048749

Fitment: 16-28mm
 Radius: 1200mm
 Replacement Glass: G450CE
 UNBREAKABLE MIRRORS

M450CE-42 model for 25-42mm diameter mirror arms also available. This may be subject to minimum quantities

M500CE

e11 II 03*6623

Fitment: 13-16mm
 Radius: 1800mm
 Replacement Glass: G500CE



M500FE

e11 III 03*6622

Fitment: 13-16mm
 Radius: Flat
 Replacement Glass: G500FE

M5000CEA4

e11 III 03*6623

Fitment: 10-20mm
 Radius: 1800mm
 Replacement Glass: G500CE



M5000CE

e11 III 03*6623

Fitment: 10-20mm
 Radius: 1800mm
 Replacement Glass: G500CE



M5000FE

e11 III 03*6622

Fitment: 10-20mm
 Radius: Flat
 Replacement Glass: G500FE



M5000CE mirror with 210mm arm and mounting bracket

See also the M5000CE-S907 mirrors on page 39

M5000CE-S1801

e11 III 03*6623

Radius
1800mm

Replacement Glass
G500CE

NEW
PRODUCT

M5000CE mirror
c/w S1801 mirror arms.
See S1800 series arm on page 50



M520CE

e11 II 03*6636

Fitment
16-22mm

Radius
1800mm

Replacement Glass
G520CE

M5201CE

e11 III 03*6637

Fitment
16-22mm

Radius
1200mm

Replacement Glass
G5201CE



Heated version available,
may be subject to minimum quantity

Spares Kit - Y2655 - see page 61

M528CE

e11 III 03*6126

Fitment
16-28mm

Radius
1800mm

Replacement Glass
G528CE



M545CE

e11 II 03*6287

Fitment
10-20mm

Radius
1800mm

Replacement Glass
G545CE



M545CEB

e11 II 03*6287

Fitment
16-28mm

Radius
1800mm

Replacement Glass
G545CE

M555CE

e11 II & III 03*6590

Fitment
10-20mm

Radius
1200mm

M555CE
Yellow

Replacement Glass
G555CE

UNBREAKABLE MIRRORS

M555CEB

e11 II & III 03*6590

Fitment
16-28mm

Radius
1200mm

M555CEB
Yellow

Replacement Glass
G555CE

UNBREAKABLE MIRRORS



Main Mirrors - Classes II & III

M600CE

e11 II 02*3701

Fitment \varnothing 16-22mm Radius 1800mm

Replacement Glass
G600CE



Heated version available, may be subject to minimum quantity

M600CESW version is supplied complete with a handwheel

M600FE

e11 II 02*3701

Fitment \varnothing 16-22mm Radius Flat

Replacement Glass
G600FE

M600CESW

e11 II 02*3701

Fitment \varnothing 16-22mm Radius 1800mm

Replacement Glass
G600CE

M602CE

e11 II 03*6626

Fitment \varnothing 16-22mm Radius 1800mm

Replacement Glass
G602CE



Heated version available, may be subject to minimum quantity

Spares Kit - Y2650 - see page 61

M610CE

e11 II 03*6643

Fitment \varnothing 16-28mm Radius 1800mm M610CE Yellow

Replacement Glass
G610CE



Heated version available, may be subject to minimum quantity

Spares Kit - Y2646 - see page 61

M6101CE

e11 III 03*6644

Fitment \varnothing 16-28mm Radius 1200mm

Replacement Glass
G6101CE

M613CE

e11 II 03*6638

Fitment \varnothing 16-22mm Radius 1800mm

Replacement Glass
G613CE



Heated version available, may be subject to minimum quantity

Spares Kit - Y2659 - see page 61

Main Mirrors - Classes II & III

M0613CE

e3 II 02*56323

Fitment 16-19mm	Radius 1800mm
--------------------	------------------

Replacement Glass
G613CE



M0613CE-Black

e3 II 02*56323

Fitment 16-19mm	Radius 1800mm
--------------------	------------------

Replacement Glass
G613CE

Heated version available, may be subject to minimum quantity

M626CE

e11 II 03*6125

Fitment 16-28mm	Radius 1800mm
--------------------	------------------

Replacement Glass
G626CE



M6261CE

e11 III 03*6125

Fitment 16-28mm	Radius 1200mm
--------------------	------------------

Replacement Glass
G6261CE

Spares Kit - Y2644 - see page 61

M640CEB

II 46R 048750

Fitment 16-28mm	Radius 1200mm
--------------------	------------------

Replacement Lens
G640CE



M701CE

e11 II 03*6625

Fitment 16-22mm	Radius 1800mm
--------------------	------------------

Replacement Glass
G701CE



Heated version available, may be subject to minimum quantity

For mounting options see mirror arms on pages 38-50



Spares Kit - Y2651 - see page 61

Main Mirrors - Classes II & III

M702CE

e11 II 03*6630

Fitment 16-22mm	Radius 1800mm	M702CE Yellow
---------------------------	-------------------------	-------------------------

Replacement Glass
G702CE



Spares Kit - Y2653 - see page 61

M703CE

E11 049212

Fitment 16-28mm	Radius 1800mm
---------------------------	-------------------------

Replacement Glass
G703CE



M714CE

e11 II 03*6639

Fitment 16-28mm	Radius 1800mm	M714CE Yellow
---------------------------	-------------------------	-------------------------

Replacement Glass
G714CE



M7141CE

e11 II 03*6640

Fitment 16-28mm	Radius 1200mm	M7141CE Yellow
---------------------------	-------------------------	--------------------------

Replacement Glass
G7141CE

M714FE

e11 II 03*6639

Fitment 16-28mm	Radius Flat
---------------------------	-----------------------

Replacement Glass
G714FE

Heated version available,
may be subject to minimum quantity

Spares Kit - Y2658 - see page 61

M725CEB

e11 II & III 03*6589

Fitment 16-28mm	Radius 1200mm	M725CEB Yellow
---------------------------	-------------------------	--------------------------

Replacement Glass
G725CE



Heated version available,
may be subject to minimum quantity

M800CE

e11 III 03*6737

Fitment
16-28mm

Radius
1800mm

Replacement Glass
G800CE



M807CE

e11 III 03*6741

Fitment
16-22mm

Radius
1800mm

Replacement Glass
G807CE



Spares Kit - Y2649 - see page 61

M820CE

e11 II 03*5957

Fitment
16-28mm

Radius
1800mm

Replacement Glass
G820CE



M8231CEB

e11 II & III 03*6921

Fitment
16-28mm

Radius
1200mm

Replacement Glass
G8231CE



Wide Angle Mirrors - Class IV, V & VI



Wide angle mirrors are used to perform different functions.

Class IV mirrors are used with a main mirror, class II or III, and give drivers greater lateral visibility.

The rendered image to the left shows the M455CE, a class IV mirror from page 20.



Class V, or kerb, mirrors are placed above the door on the nearside of a vehicle and allow drivers to see the blind spot at the side of the road.

The image to the right shows an Ashtree wide angle mirror mounted onto a S1800 series mirror arm.



Class VI mirrors give the driver visibility across the front of the vehicle.

These two images show an entire class of school children who were invisible to the driver without the use of an Ashtree class VI mirror.

Wide Angle Mirrors - Class IV, V & VI

M238CE

e11 IV & V 03*6320

Fitment
16-28mm

Radius
450mm

Replacement Glass
G238CE



M2381CE

e11 IV & V 03*6320

Fitment
16-28mm

Radius
300mm

Replacement Glass
G2381CE

Spares Kit - Y2645 - see page 61

M250CE

e11 IV & V 03*6843

Fitment
10-20mm

Radius
300mm

M250CE Yellow

Replacement Glass
G250CE

UNBREAKABLE MIRRORS



M250CEB

e11 IV & V 03*6843

Fitment
16-28mm

Radius
300mm

M250CEB Yellow

Replacement Glass
G250CE

UNBREAKABLE MIRRORS

M430CE

e11 IV 03*6404

Fitment
10-20mm

Radius
300mm

Replacement Glass
G430CE

UNBREAKABLE MIRRORS



M430CEB

e11 IV 03*6404

Fitment
16-28mm

Radius
300mm

Replacement Glass
G430CE

UNBREAKABLE MIRRORS

M430CEA1

e11 IV 03*6404

Radius
300mm

Replacement Glass
G430CE

The M430CEA1 comes complete with the S1090 arm.



Arm with 2 x 6mm slots at 40-60mm centres

S1090

Arm Only

M3102CE

e11 IV 03*6633

Fitment
10-20mm

Radius
450mm

Replacement Glass
G4102CE



M3102CEB

e11 IV 03*6633

Fitment
16-28mm

Radius
450mm

Replacement Glass
G4102CE

Wide Angle Mirrors - Class IV, V & VI

M435CE

e11 IV & V 03*6588

Fitment \varnothing 10-20mm Radius 300mm

Replacement Glass G435CE



M435CE- Stud

e11 IV & V 03*6588

Fitment M6 Stud Radius 300mm

Replacement Glass G435CE



M4402CE

e11 IV & V 03*8012

Fitment \varnothing 10-20mm Radius 450mm

Replacement Glass G4402CE UNBREAKABLE MIRRORS



M4402CEB

e11 IV & V 03*8012

Fitment \varnothing 16-28mm Radius 450mm

Replacement Glass G4402CE UNBREAKABLE MIRRORS

M455CE

IV 46R 048748

Fitment \varnothing 10-20mm Radius 300mm

Replacement Glass G455CE

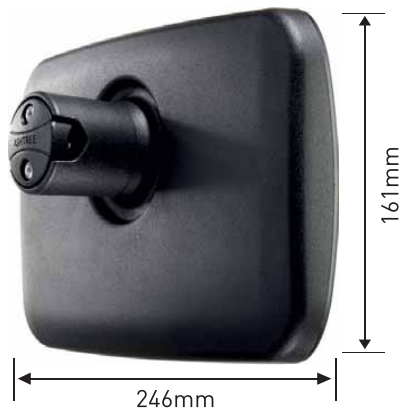

M455CEB

IV 46R 048748

Fitment \varnothing 16-28mm Radius 300mm

Replacement Glass G455CE

M504CE

e11 IV 02*5465

Fitment \varnothing 16-22mm Radius 450mm

Replacement Glass G504CE



M504CEA

e11 V 02*5465

Radius 450mm

Replacement Glass G504CE

M504CEA is the M504CE mirror complete with the S1216 arm

S1216

Arm only



Arm with 2 x 7mm slots at 75-80mm centres

Wide Angle Mirrors - Class IV, V & VI

MX550CE

e11 VI 03*6447

Fitment
10-20mm

Radius
250mm



Unbreakable lens

MX550CEB

e11 VI 03*6447

Fitment
16-28mm

Radius
250mm

MX550CEA

e11 VI 03*6447

Radius
250mm

The MX550CEA comes complete with the S1091 arm. This is 440mm long and is 19mm in diameter. The clamp will fit arms of 16-28mm. This arm is available as a separate component.

S1091

Arm only



MX550CEA3

e11 VI 03*6447

Radius
250mm



Unbreakable lens. Universal class VI mirror kit complete with arm and mounting bracket suitable for vertical or horizontal fitment.

M5601CE

e11 VI 46R 048505

Fitment
10-20mm

Radius
300mm



M5601CEA

e11 VI 46R 048505

Fitment
10-20mm

Radius
300mm



"B" versions of both mirrors are available with a clamp that fits 16-28mm diameter mirror arms

S1091

Arm only

The M5601CEA comes complete with the S1091 arm. This is 440mm long and is 19mm in diameter. The clamp will fit arms of 16-28mm. This arm is available as a separate component.



MX635CE

e11 VI 03*6343

Fitment
10-20mm

Radius
225mm

MX6351CE

e11 IV & V 03*6343

Fitment
10-20mm

Radius
330mm



Unbreakable lens

"B" versions of both mirrors are available with a clamp that fits 16-28mm diameter mirror arms. See also S1400 & S1412 on page 47

Unbreakable Mirrors



Ashtree are Europe's largest designers and manufacturers of unbreakable mirrors and we have the largest range of products to cover many different uses and applications.



As with all our mirrors our unbreakable range is designed for universal fitment. We have clamps that will go from 10-20mm diameter, 16-28mm diameter and, in some cases, all the way up to 42mm diameter bars.

MX250CE

e11 IV & V 03*6843

Fitment ∅ 10-20mm	Radius 300mm	MX250CE Yellow
-------------------------	-----------------	-------------------

Replacement Lens
GX250CE



208mm
208mm

MX250CEB

e11 IV & V 03*6843

Fitment ∅ 16-28mm	Radius 300mm	MX250CEB Yellow
-------------------------	-----------------	--------------------

Replacement Lens
GX250CE

MX430CE

e11 IV 03*6404

Fitment ∅ 10-20mm	Radius 300mm
-------------------------	-----------------

Replacement Lens
GX430CE



240mm
155mm

MX430CEB

e11 IV 03*6404

Fitment ∅ 16-28mm	Radius 300mm
-------------------------	-----------------

Replacement Lens
GX430CE

MX4402CE

e11 IV & V 03*8012

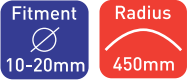

MX4402CEB

e11 IV & V 03*8012

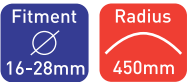

MX450CE

II 46R 048749



MX450CEB

II 46R 048749



MX440CE

e11 II & III 03*6619

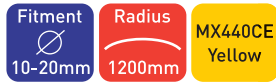

MX440CEB

e11 II & III 03*6619



MX550CE

e11 VI 03*6447



MX550CEB

e11 VI 03*6447

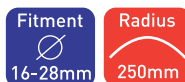

Unbreakable Mirrors

MX555CE

e11 II & III 03*6590

Fitment: 10-20mm | Radius: 1200mm | MX555CE Yellow

Replacement Lens: GX555CE



MX555CEB

e11 II & III 03*6590

Fitment: 16-28mm | Radius: 1200mm | MX555CEB Yellow

Replacement Lens: GX555CE



MX5601CE

e11 VI 46R 048505

Fitment: 10-20mm | Radius: 300mm



Subject to quantity the MX5601CEB version, with a clamp for 16-28mm diameter arms is available
Also the MX5601CE-42 which fits directly onto arms up to 42mm in diameter

MX635CE

e11 VI 03*6343

Fitment: 10-20mm | Radius: 225mm



MX6351CE

e11 IV & V 03*6343

Fitment: 10-20mm | Radius: 330mm



"B" versions of both mirrors are available with a clamp that fits 16-28mm diameter mirror arms.
See also S1400 & S1412 on page 60

MX640CEB

II 46R 048750

Fitment: 16-28mm | Radius: 1200mm | MX640CEB Yellow

Replacement Lens: GX640CE



MX725CEB

e11 II & III 03*6589

Fitment \varnothing 16-28mm Radius 1200mm MX725CEB Yellow

Replacement Lens
GX725CE



MX943

Fitment \varnothing 10-20mm Radius 100mm



MX948

Fitment \varnothing 10-20mm Radius 150mm



MX948B

Fitment \varnothing 16-28mm Radius 150mm



Twin Lens, Powered and Adjustable Mirrors



Powered mirrors are popular on vehicles and machines where it's not practical for the driver to adjust a standard mirror or where two different fields of visibility are required. Ashtree have both single and twin lens mirrors for this purpose. Part number M926CE, seen left and below, can be used on construction machinery and also small trucks and buses.

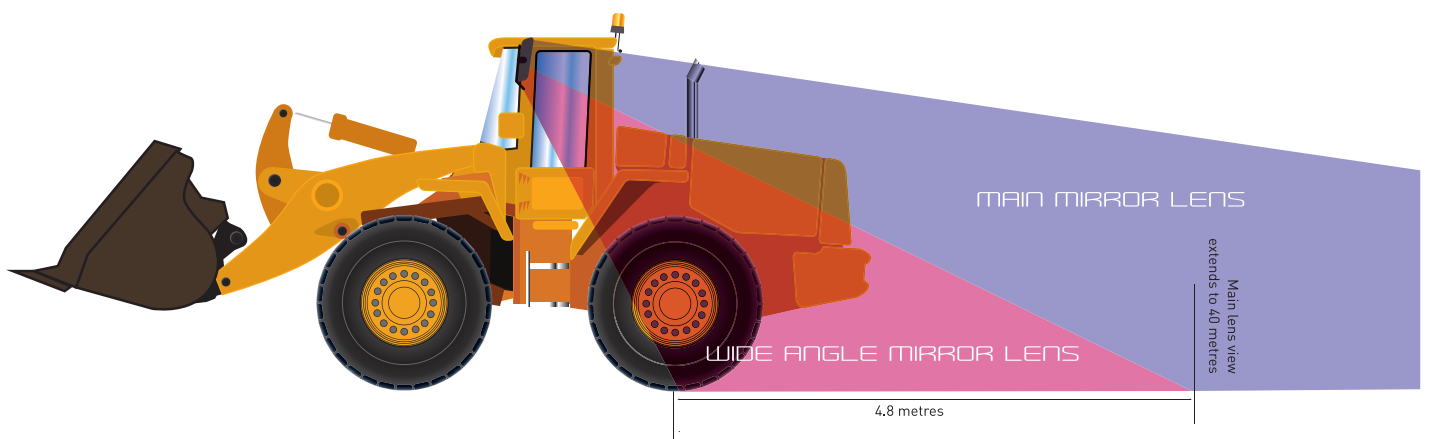
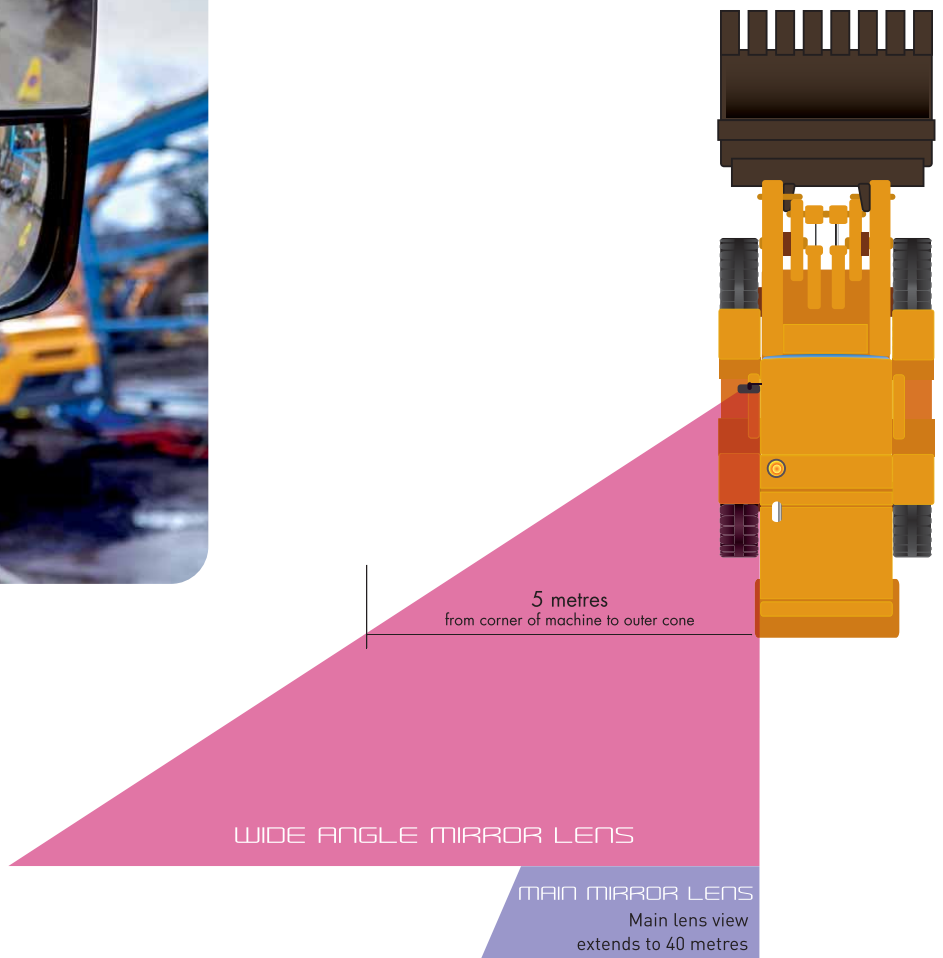

Twin Lens, Powered and Adjustable Mirrors

M912CEH

e11 II 03*6645

Fitment \varnothing 16-28mm Radius 1800mm

Replacement Glass G714CEHc



Single lens, electrically adjustable & heated

These parts are 24V, please ask if a 12v option is required

If required, the Y2675 cable and Y2677 switches can be used to power/operate this mirror

M915CEH

e11 III 03*6203

Fitment \varnothing 16-28mm Radius 1800mm

Replacement Glass G714CEHc



M9151CEH

e11 III 03*6203

Fitment \varnothing 16-28mm Radius 1200mm

Replacement Glass G7141CEHc

M916CEH

e11 II 03*6203

Fitment \varnothing 16-28mm Radius 1800mm

Replacement Glass G714CEHc

M915CEH & M9151CEH

Single lens, electrically adjustable & heated

M916CEH

Single lens, hand adjustable & heated

These parts are 24V, please ask if a 12v option is required

If required, the Y2675 cable and Y2677 switches can be used to power/operate this mirror

M922CEH

e11 II IV 03*6641

Fitment \varnothing 16-28mm Radius 1800mm Main Lens
Radius 300mm Wide Angle Lens

Replacement Glass G536CEHc Replacement Glass G2231CEHc



Power adjustable & heated main lens
Fixed/heated wide angle lens

These parts are 24V, please ask if a 12v option is required

If required, the Y2675 cable and Y2677 switches can be used to power/operate this mirror

Y2675

6 way plug with 2 metre cable



Y2677-24

24 volt switch

Y2677-12

12 volt switch

4 way mirror adjustment switch (both sides). Complete with 2 metres of cable
Dimensions: 47mm x 38mm to fit hole 44mm x 33mm



Twin Lens, Powered and Adjustable Mirrors

M923CEH

e11 II IV 03*6641

Fitment 16-28mm **Radius** 1800mm Main Lens

Radius 300mm Wide Angle Lens

Replacement Glass G536CEHc
Replacement Glass G2231CEHc



M9231CEH

e11 II IV 03*6642

Fitment 16-28mm **Radius** 1200mm Main Lens

Radius 300mm Wide Angle Lens

Replacement Glass G5361CEHc
Replacement Glass G2231CEHc

Both versions are hand adjustable & heated

Please ask if a 12v model is required

M925CEH

E11 II, III & IV 048173

Fitment 16-28mm **Radius** 1200mm Main Lens

Radius 300mm Wide Angle Lens

Replacement Glass GW433CEH 12v or 24v MAIN LENS
Replacement Glass GW232CEH 12v or 24v WIDE ANGLE LENS



M925CEH-24 - 24v Power adjustable and heated
M925CEH-12 - 12v Power adjustable and heated

Y2678 switch and 2 x Y3107 are required to adjust/power the M925 series mirrors

M926CE

E11 II, III & IV 048173

Fitment 16-28mm **Radius** 1200mm Main Lens

Radius 300mm Wide Angle Lens

M926CE Yellow

Replacement Glass GW433CE MAIN LENS
Replacement Glass GW232CE WIDE ANGLE LENS



M926CE - Manually adjustable

M926CEH - Manually adjustable and 24v heated

M926CEH-12 - Manually adjustable and 12v heated

Requires the Y3098 cable to run power to the mirror

Y2678



12-24 volt switch to operate 2 x twin lens mirrors, with 2 metre cable

Y3107



6 pin male round plug with 3.5m wire for use with M925CEH mirrors. Two cables required for each mirror

Y3098



2 pin male plug with 1.5m wire for use with M926CEH mirrors. One cable required for each mirror

Twin Lens, Powered and Adjustable Mirrors

M930CEH

E11 46R04/09*9211*00

- Fitment** 19-25mm
- Radius** 1200mm **Main Lens**
- Radius** 300mm **Wide Angle Lens**



Y3107

6 pin male round plug with 3.5m wire for use with M930CEH mirrors



Y2683

12/24 volt switch for left and right mirrors, complete with 45cm cable



M930CEH-12 Heated and 12v powered adjustable-main lens only
M930CEH-24 Heated and 24v powered adjustable-main lens only

M935CEH

E11 46R04/09*9211*00

- Fitment** 19-25mm
- Radius** 1200mm **Main Lens**
- Radius** 300mm **Wide Angle Lens**



M935CEH-12 Manually adjustable with 12v heating
M935CEH-24 Manually adjustable with 24v heating

Y3098

Y3098 cable required to run power to heated models



A 3d simulation shows how Ashtree twin lens mirrors can be used to give visibility of areas where there would otherwise be a blind spot

Interior Mirrors

Interior mirrors enhance visibility for drivers and operators. They can be used to gain 180-degree visibility, like our MX943 mirror, or to focus on a particular blind spot. We have a wide range of mirrors, covering many applications and also mounting brackets, such as our S1230, on page 33.



M2000CEA2

e11 III 03*6624

Radius
1200mm

Replacement Glass
G200CE

M2000FEA2

e11 III 03*6624

Radius
Flat

Replacement Glass
G200FE



Mounting bracket has two M6 slots that fasten at 40-60mm centres

M235C

Fitment
M6 Stud
Radius
200mm



M310CEA1

e11 I 03*6632

Radius
1200mm

Replacement Glass
G410CE

M310FEA1

e11 I 03*6632

Radius
Flat

Replacement Glass
G410FE



Mounting bracket has two 7mm slots at 75-80mm centres

M435CE

e11 IV & V 03*6588

Fitment
10-20mm
Radius
300mm

Replacement Glass
G435CE



M435CE-Stud

e11 IV & V 03*6588

Fitment
M6 Stud
Radius
300mm

Replacement Glass
G435CE



M3102CEA1

e11 V 03*6633

Radius
450mm

Replacement Glass
G4102CE

Interior Mirrors

M435CEA2

e11 IV & V 03*6588

Radius
300mm

Replacement Glass
G435CE



Mounting bracket has two M6 slots that fasten at 40-60mm centres

M631CA

with S1173 mirror arm

Radius
1800mm

M631

Mirror head only

Fitment
10-20mm

Radius
1800mm



S1173

Arm and bracket only



Mounts onto 35mm diameter poles

MX943

Fitment
10-20mm

Radius
100mm



MX943A2

Radius
100mm



Mounting bracket has two M6 slots that fasten at 40-60mm centres

Interior Mirrors

M245C

Mirror only

Fitment 10-20mm	Radius 450mm
---------------------------	------------------------



S1173

Arm and bracket only



S1173 arms can be used if this mirror is to be used as an observation mirror on buses.

Mounts onto 35mm diameter poles

S1230

This mirror arm can be used for mounting mirrors onto a horizontal or vertical surface. Adjust the arm to the correct angle and then tighten the bolt in the bracket to create a stable mounting point for your mirror.



M560C

Mirror only

Fitment 10-20mm	Radius 450mm
---------------------------	------------------------



S1173

Arm and bracket only



S1173 arms can be used if this mirror is to be used as an observation mirror on buses.

Mounts onto 35mm diameter poles

M5601CE

e11 VI 46R 048505

Fitment 10-20mm	Radius 300mm
---------------------------	------------------------



M5601CEA

e11 VI 46R 048505

Fitment 10-20mm	Radius 300mm
---------------------------	------------------------



"B" versions of both mirrors are available with a clamp that fits 16-28mm diameter mirror arms

See MX5601CE on page 24

Safety Mirrors



Stricter visibility standards, driven by the desire to reduce accidents, mean that better visibility is more and more important. Ashtree have a wide range of mirrors and brackets to help make workplaces safer. With clamps that fit bars of 10mm-42mm in diameter we should have something for most applications.

Ashtree mirrors are used on many different machines including tractors, loading shovels, telehandlers, truck mounted forklifts and materials handling equipment.



M245C-42

Fitment \varnothing 25-42mm
Radius 450mm



This mirror is available with different radii of glass - may be subject to minimum quantities.

M560C-42

Fitment \varnothing 25-42mm
Radius 450mm



This mirror is available with different radii of glass - may be subject to minimum quantities.

MX941

Unbreakable lens

Fitment \varnothing 13-16mm
Radius 450mm

MX941A

Unbreakable lens

Radius 450mm

MX941B

Unbreakable lens

Fitment \varnothing 16-28mm
Radius 450mm



MX941B complete with clamp for fitment to 16-28mm diameter arms



MX941A Complete with arm that has 2 x 7mm slots at 75-80mm centres

M5601CE

e11 VI 46R 048505

Fitment \varnothing 10-20mm
Radius 300mm

M5601CEA

e11 VI 46R 048505

Fitment \varnothing 10-20mm
Radius 300mm



"B" versions of both mirrors are available with a clamp that fits 16-28mm diameter mirror arms

Safety Mirrors

MX942

Unbreakable lens

Fitment 13-16mm	Radius 100mm
--------------------	-----------------



MX942A

Radius 100mm



Complete with arm that has 2 x 7mm slots at 75-80mm centres

MX942B

Unbreakable lens

Fitment 16-28mm	Radius 100mm
--------------------	-----------------



MX943

Unbreakable lens

Fitment 10-20mm	Radius 100mm
--------------------	-----------------



MX635CE

e11 VI 03*6343

Fitment 10-20mm	Radius 225mm
--------------------	-----------------



MX6351CE

e11 IV & V 03*6343

Fitment 10-20mm	Radius 330mm
--------------------	-----------------

Unbreakable lens

"B" versions of both mirrors are available with a clamp that fits 16-28mm diameter mirror arms.
See also S1400 & S1412 on page 60

MX5601CE

e11 VI 46R 048505

Fitment 10-20mm	Radius 300mm
--------------------	-----------------



Subject to quantity the MX5601CEB version, with a clamp for 16-28mm diameter arms is available
Also the MX5601CE-42 which fits directly onto arms up to 42mm in diameter

Safety Mirrors

MX948

Unbreakable lens

Fitment	Radius
10-20mm	150mm

MX948B

Unbreakable lens

Fitment	Radius
16-28mm	150mm



MX950-Tunnel

Unbreakable lens

Fitment	Radius
19mm Stem	125mm - 185mm

MX951-Tunnel

Unbreakable lens

Fitment	Radius
19mm Stem	125mm - 185mm

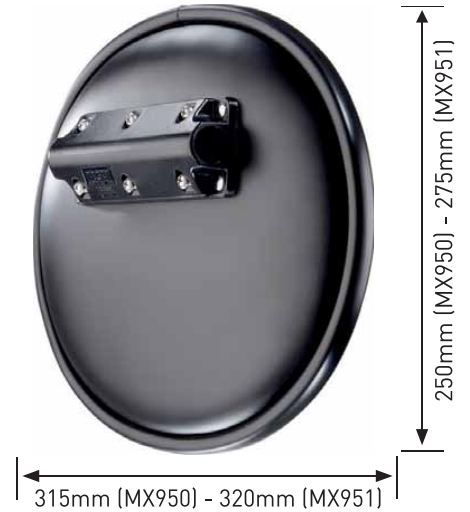

MX950-Stud

Unbreakable lens

Fitment	Radius
3/8" UNC STUD	125mm - 185mm

MX951-Stud

Unbreakable lens

Fitment	Radius
3/8" UNC STUD	125mm - 185mm



MX952

Unbreakable lens

Fitment	Radius
Twin Stud at 115mm	200mm

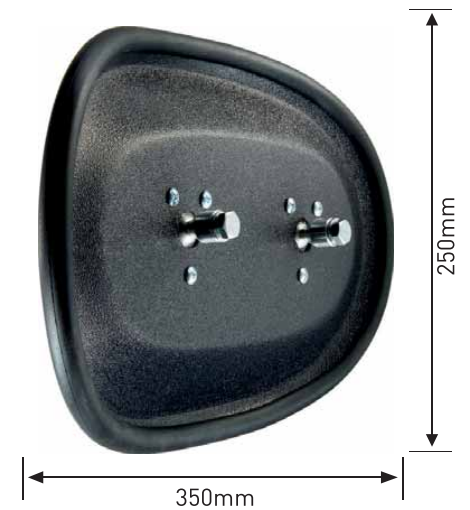

S1413

Arm only

Bracket for mounting the MX952 onto arms of 28mm diameter. Two pieces required per mirror.



MX950B and MX951B versions come complete with clamp for fitment to 16-28mm diameter mirror arms

Mirror Arms



The ever increasing range of Ashtree mirror arms are used in many different industries and applications. They vary in size from 16mm all the way up to 28mm diameter and come with different styles of mounting styles.

To keep pace with demand we have installed a new tube bending machine and also an automatic welding robot.

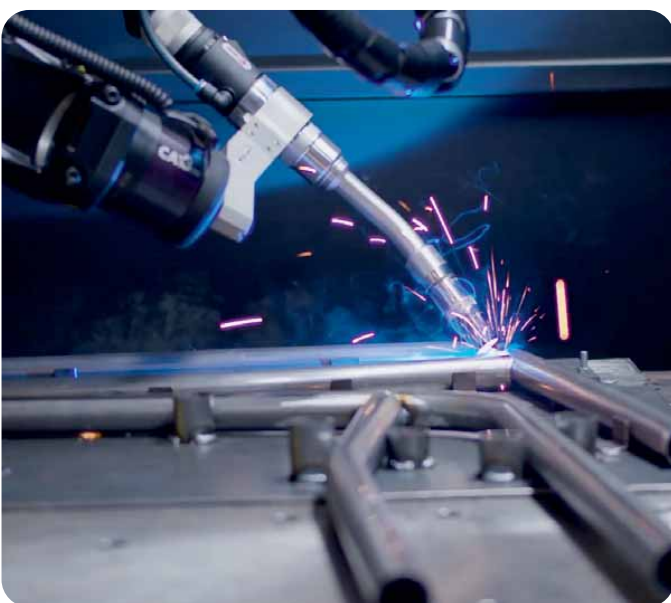

Ashtree's S900 series of arms are designed to be both strong and flexible. The main body is moulded from a high impact polymer for greater strength, less vibration and a lower weight but the arms have two sets of opposing teeth made of zinc. This design feature helps to reduce wear between the two surfaces when the arms index. Most other mirror arms index at 45 degree increments, at best, but the S900 range adjust at 20 degree increments. This helps obtain the best possible viewing position for the mirror. Mounting the mirror couldn't be simpler. There are three M6 threaded holes set at either 45mm or 60mm centres or part number Y2089 can be used to mount them externally.

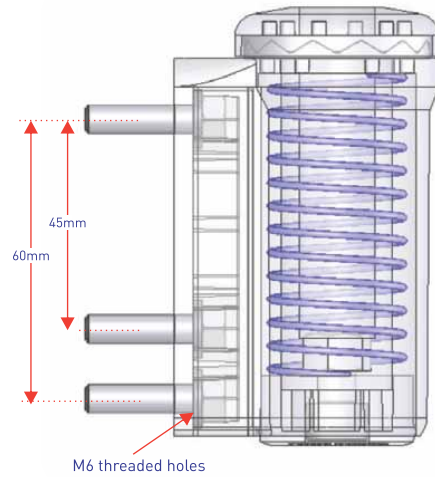

Individual arms S907L & S907R

M5000CE-S907L
M5000CE-S907R

The S900 series of mirror arms are protected by UK patent GB2474435B

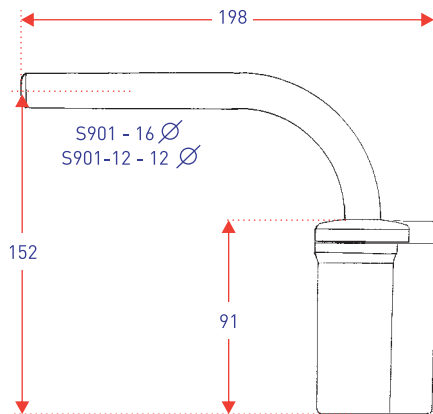

S901 & S901-12

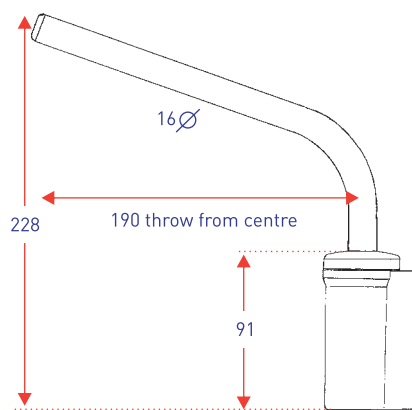

S902

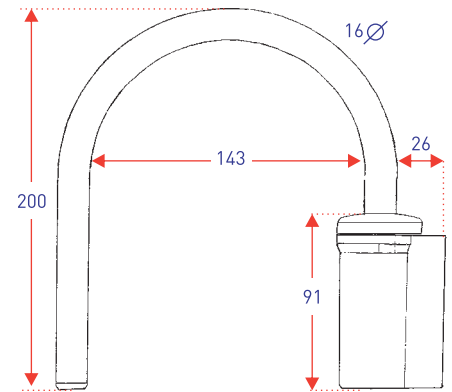

S903

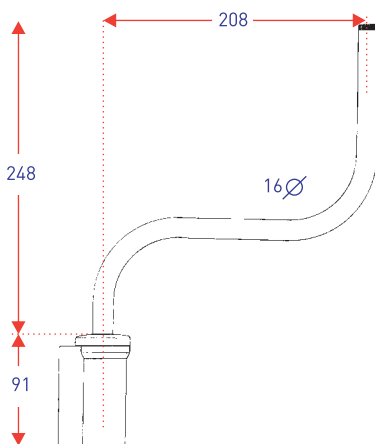

S904

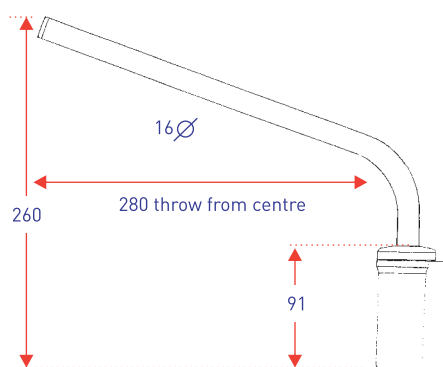

S905

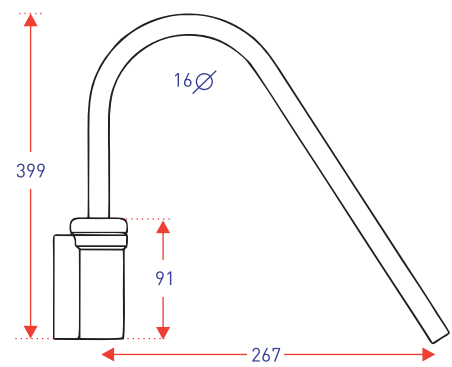

S920

Mirror Arms Desmo

These arms were originally manufactured by Desmo until the purchase of the Desmo business by Ashtree in 1989, when production was moved to Bradford. For many years they were the standard arm used in the UK bus industry and are still widely used on construction equipment and municipal vehicles. With an all zinc, diecast, body the 16mm diameter tube will adjust in 45 degree increments. The cap has three threaded holes so the arms can be adjusted to a new start point, 15 degrees on either side of the factory set position, to make it easier to get the best possible field of visibility. These arms are mounted on two M6 threaded holes at 60mm centres.



All dimensions in mm unless otherwise stated

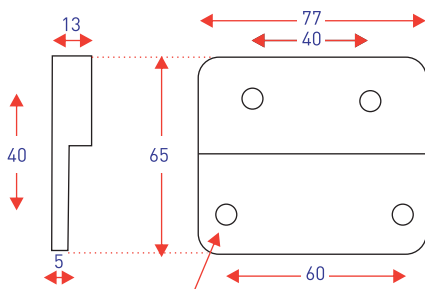

4 x 7 DIA HOLES SPACED AS SHOWN

MOUNTING BRACKET FOR
DESMO and S900 16mm ARMS

Y2089

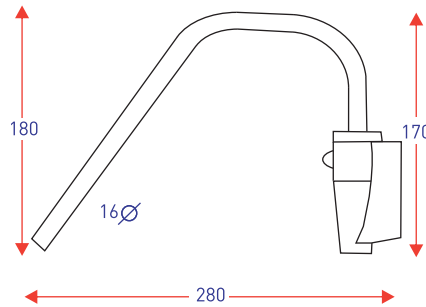

S1186

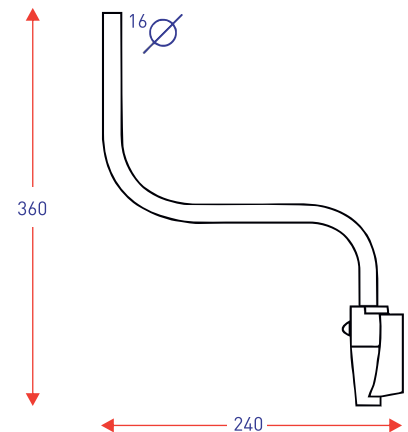

S1187

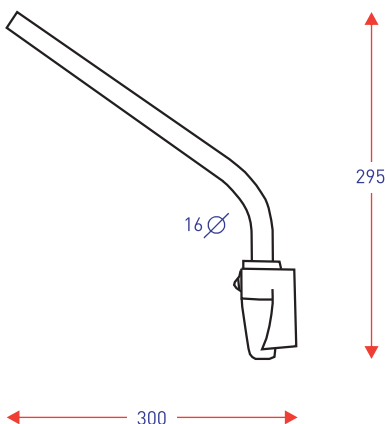

S1190

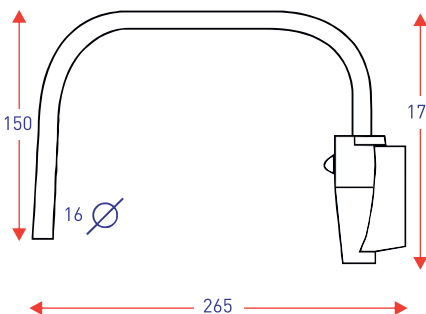

S1191

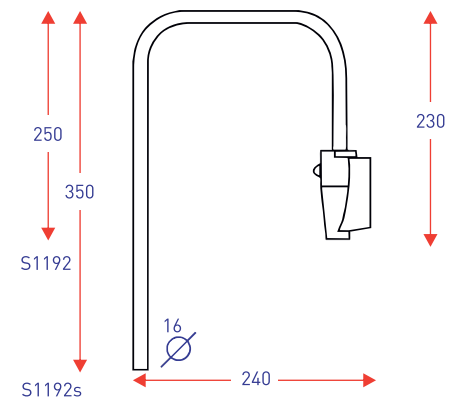

S1192 & S1192s

Mirror Arms Desmo

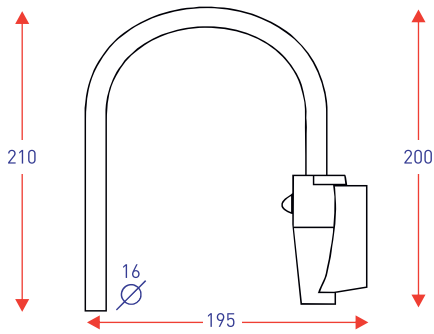

S1193

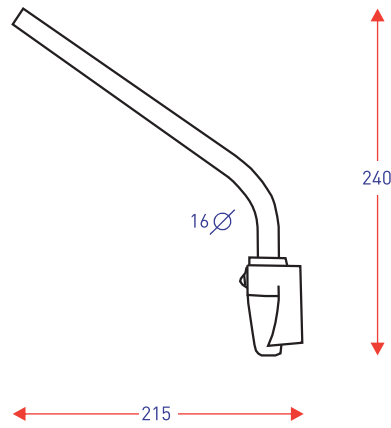

S1194

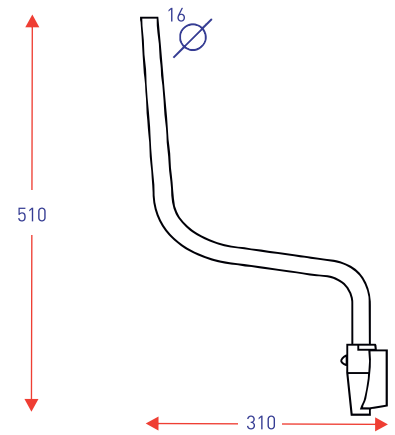

S1195

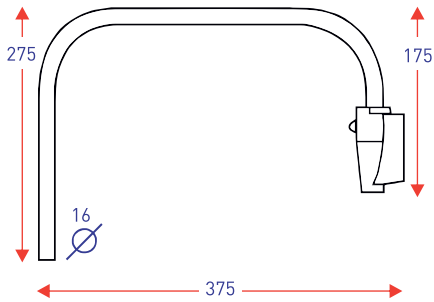

S1196

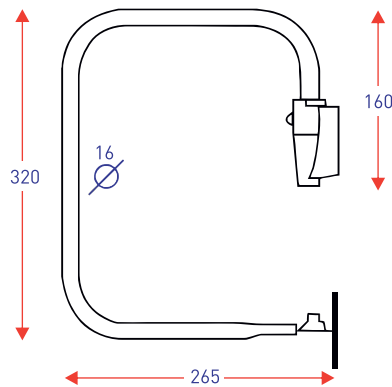

S1198

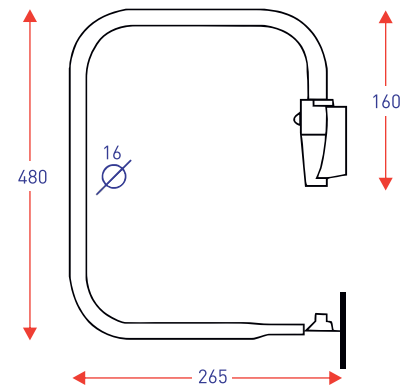

S1198s

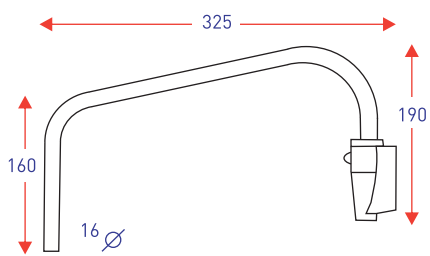

OPTARE

S1200

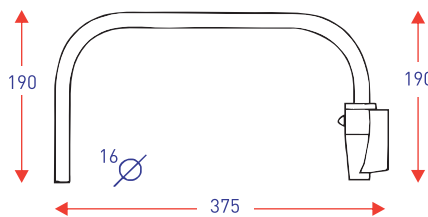

OPTARE

S1201

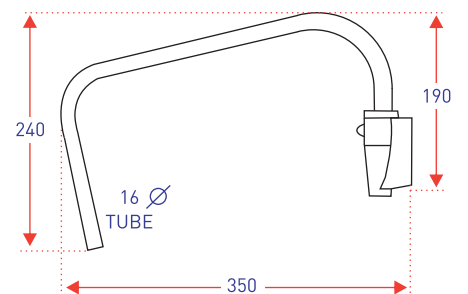

CONSTRUCTION EQUIPMENT

S1222

Mirror Arms S1300

The Ashtree S1300 range of mirror arms use 19mm diameter tube and were originally designed with buses in mind. Such is their strength that we now manufacture them for use on construction equipment and other off highway machinery. The diecast indexing bracket indexes at 22.5 degrees, having 16 different positions in a full 360 degree circle. They mount onto vehicles on a tapered slide and fit onto part numbers Y2670-3 or Y2670-4. These, 3 and 4 hole, wedges have hole configurations which are the same as other popular models on the market. Both of the Ashtree wedges come complete with a fitted grub screw. If needed, this can be tightened to help prevent theft of the arms when in use.

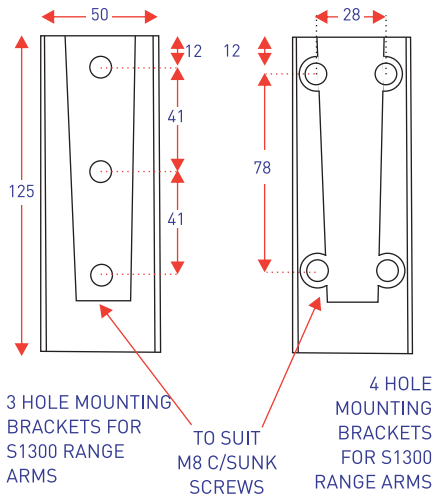

Y2670-3 / Y2670-4

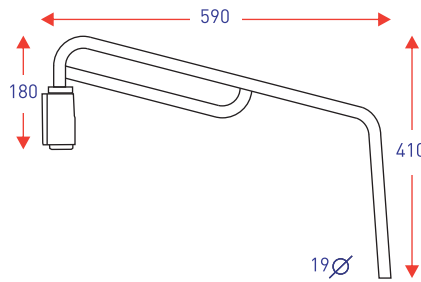

S1350

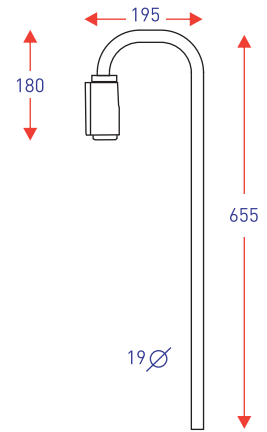

S1352

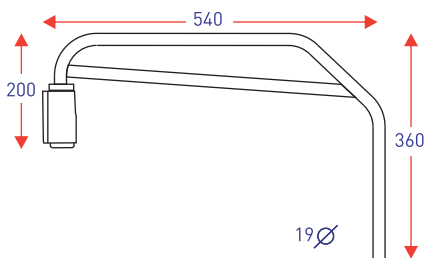

S1360

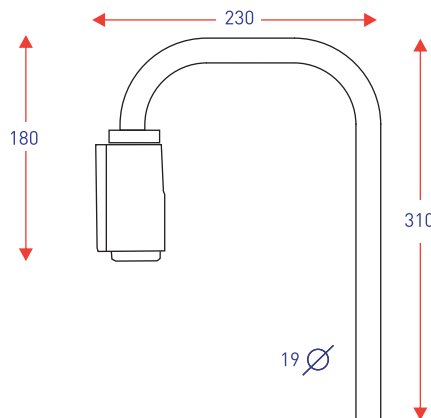

S1361

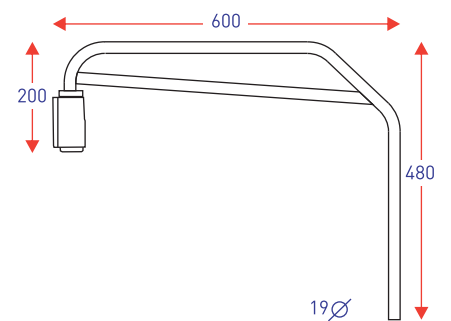

S1370

Mirror Arms S1300

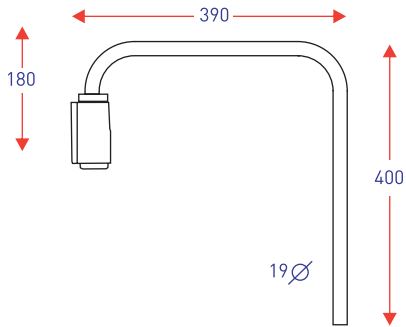

S1372

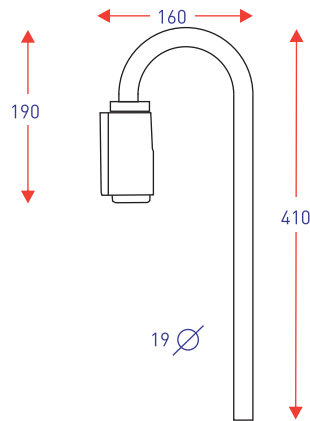

S1374

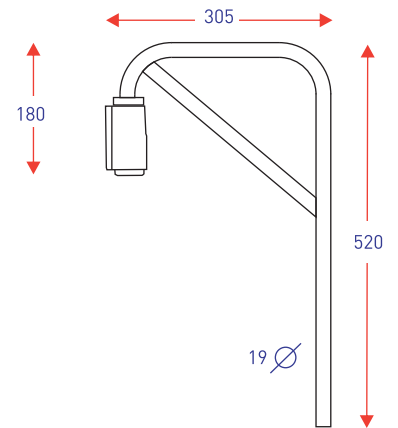

S1375

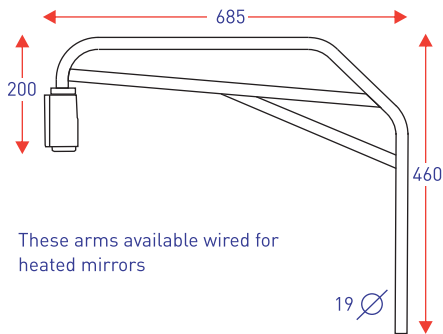

S1376

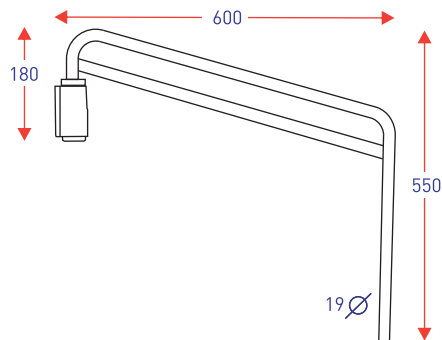

S1377

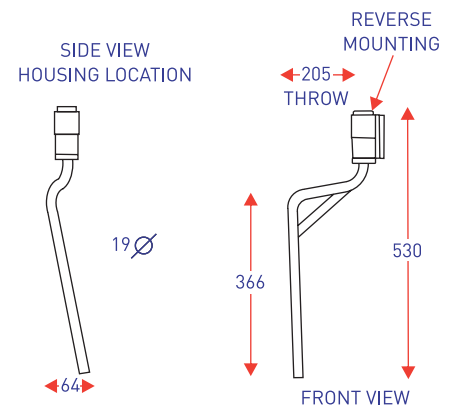

S1378

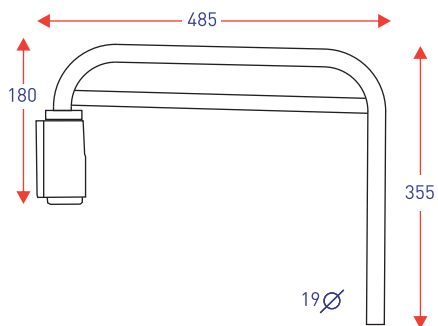

S1381

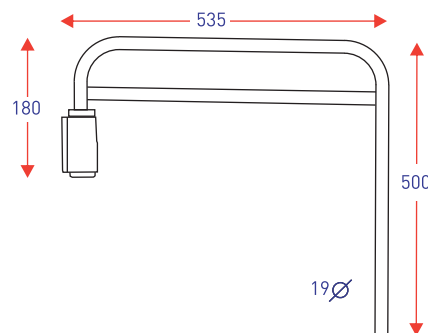

S1382

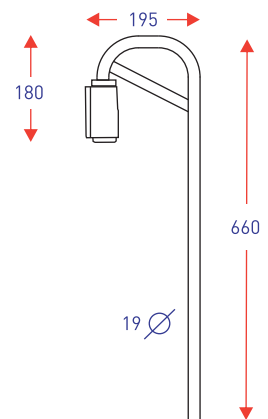

S1384

Mirror Arms S1300

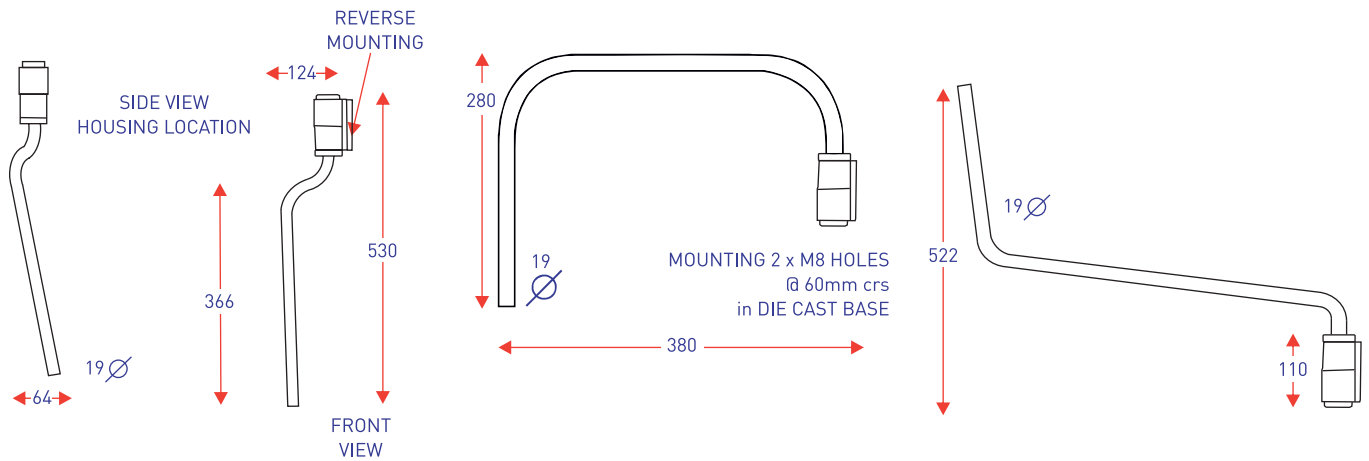

S1385

S1390

S1397

Ashtree mirrors and arms are used by busbuilders around the world.



Mirror Arms S1500

The Ashtree S1500 range of arms use parallel 28mm steel tubes to provide greater stability on the longer mirror arms widely used these days. The arms adjust at 72 degree increments but can be micro adjusted by means of Ashtree's unique system. Two screws are mounted in the main body of the arm, by loosening one, and then tightening the other, the arm can be set to the exact position required. There is also a screw set into the body that allows the arms to be locked into position to help prevent theft.

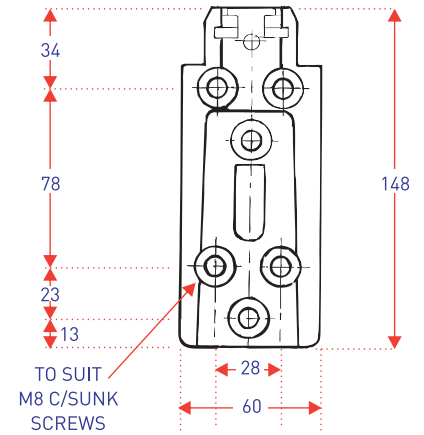

Y2672

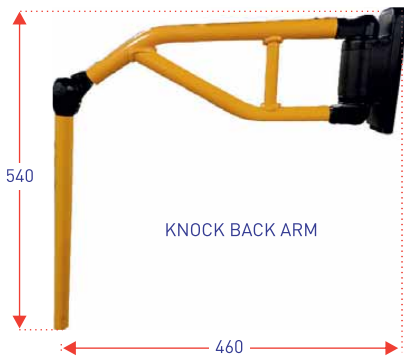

KNOCK BACK ARM

S1500-46/54-YELLOW

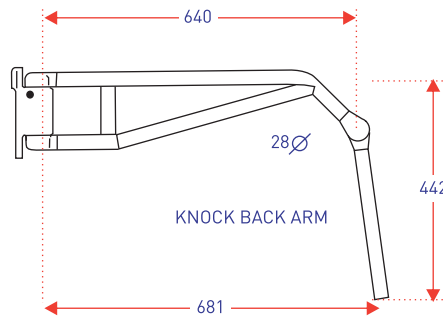

KNOCK BACK ARM

S1500-64/44

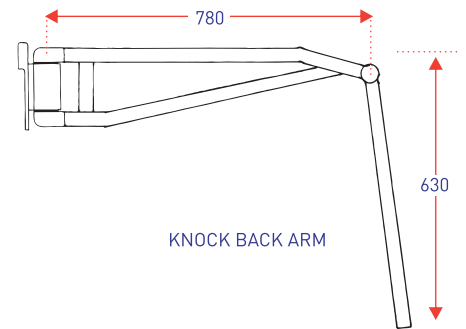

KNOCK BACK ARM

S1500-78/63

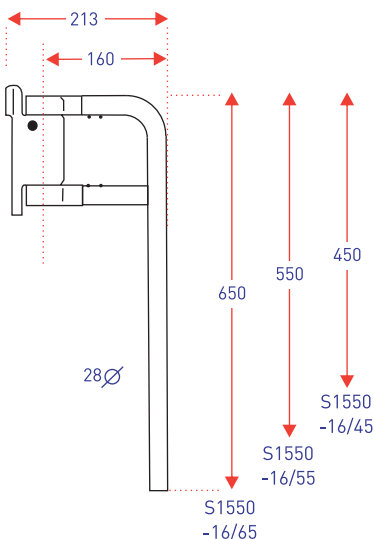

**S1550-16/45
S1550-16/55
S1550-16/65**

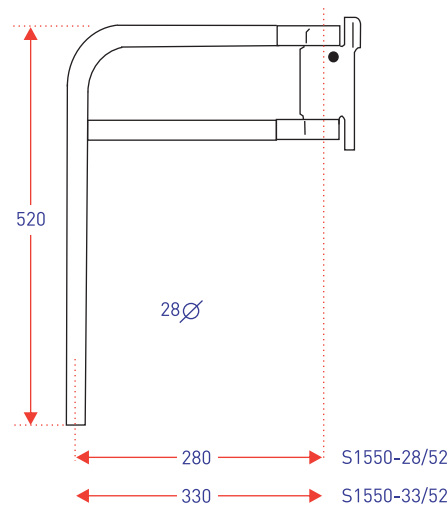

**S1550-28/52
S1550-33/52**

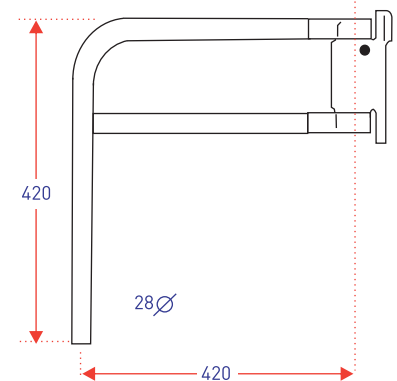

S1550-42/42

Mirror Arms S1500

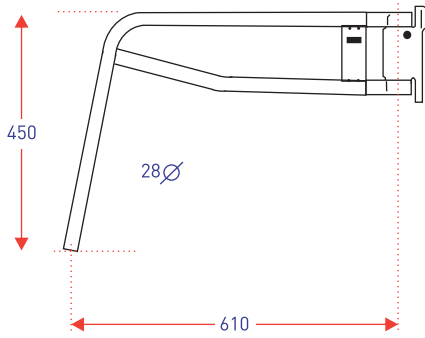

S1550-61/45

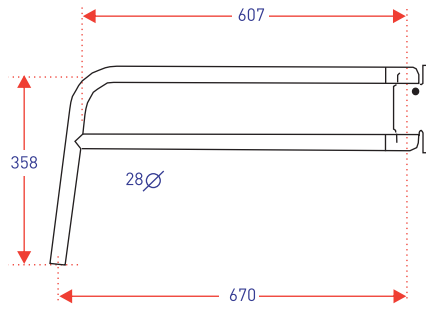

S1550-66/37

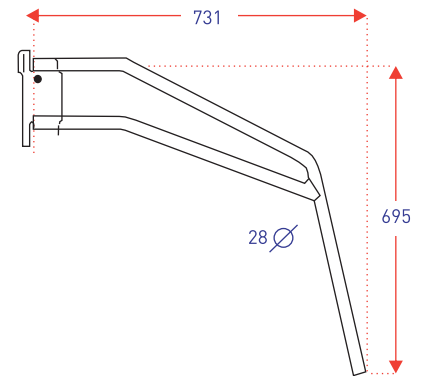

S1550-73/69

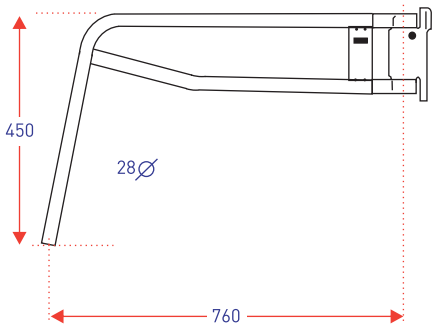

S1550-76/45

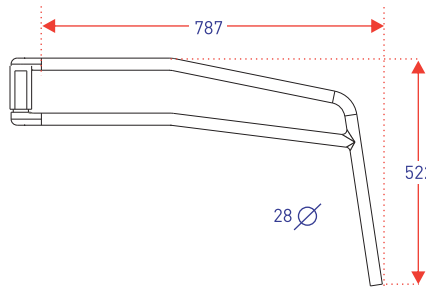

S1550-79/52

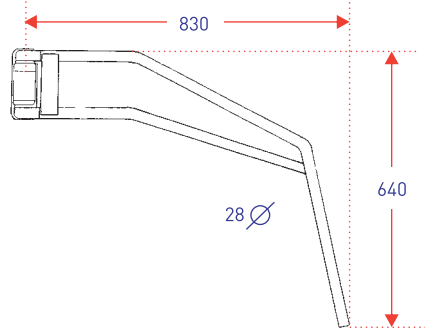

S1550-83/64

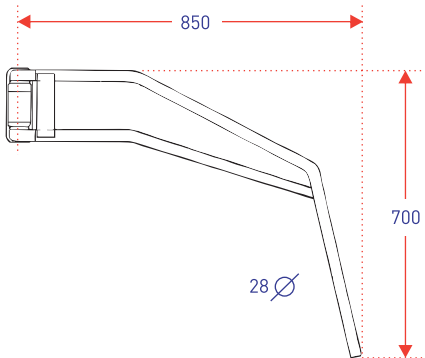

S1550-85/70

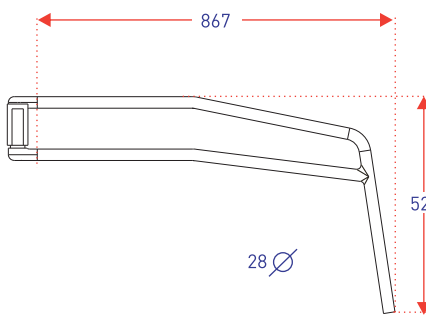

S1550-86/52

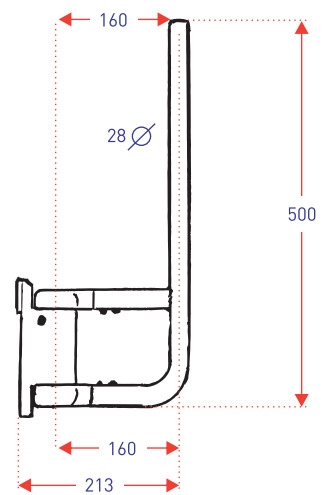

S1551-16/50

The Ashtree S1600 arms are designed for vehicles and machines that need something larger than the S900 series. The S1600 series of mirror arms are protected by UK patent GB2474435B

Mirror Arms S1600

They mount on 2 x M8 threaded holes at 60mm centres. For applications where the arms need to be removed a bolt on wedge, part number Y2242, can be added and then the arm will slide on and off of part numbers Y2670-3 or Y2670-4.

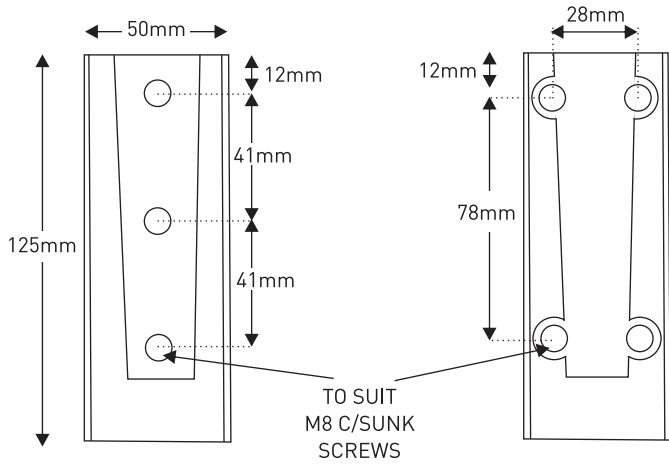

Y2670-3

Y2670-4



Y2242

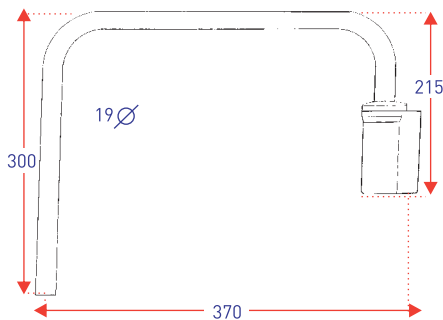

S1601

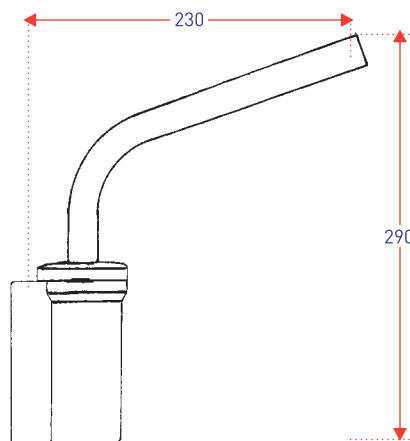

S1602

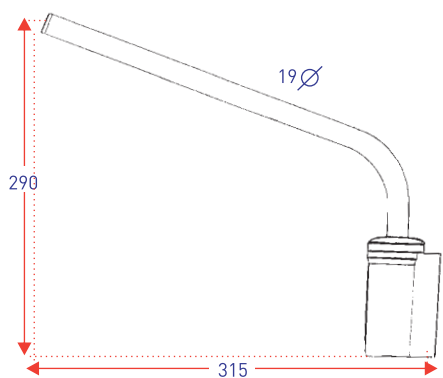

S1603

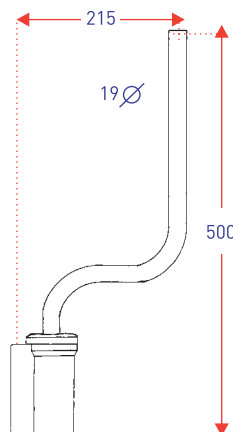

S1604

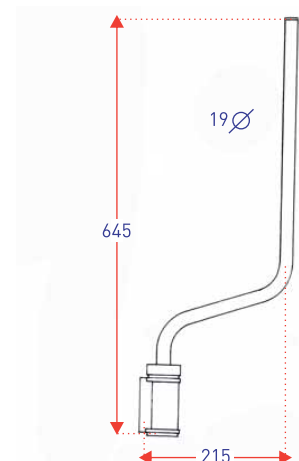

S1605



Mirror Arms S1700

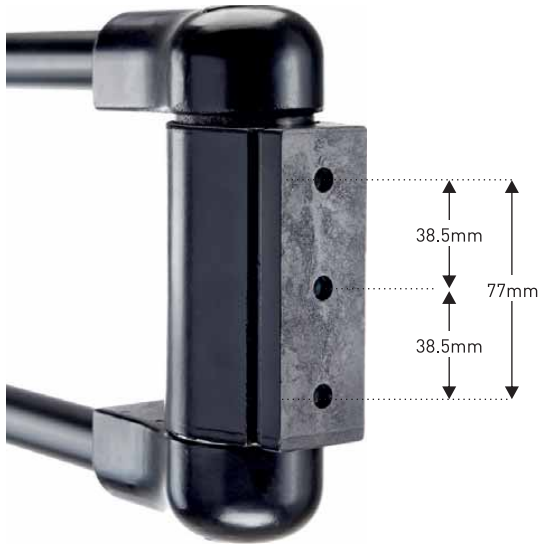

The Ashtree S1700 range of mirror arms are dual support mirror arms designed for heavy duty applications.

If removal of the arm from the machine is required, the Y3123 can be fitted to the arm. This will slide on/off the Y3124 which is a four-hole bracket.

The S1700 series of mirror arms are protected by UK patent GB2474435B



Y3123



Y3124

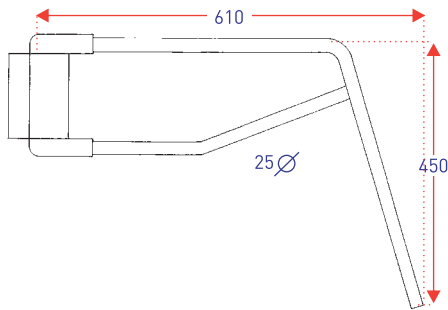

S1750-61/45

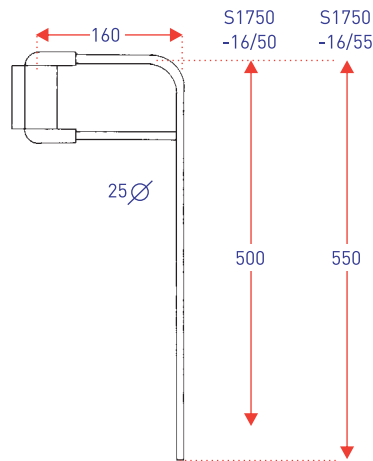

S1750-16/50
S1750-16/55

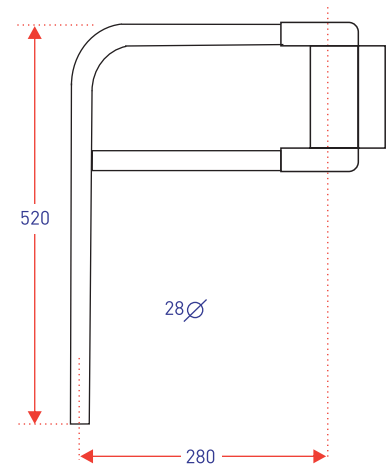

S1750-28/52



arm locates onto
**OEM or
aftermarket**
existing footprints

The Ashtree, S2000 series, extending arms are suitable for use on the existing footprint of popular models making them suitable for replacement parts as well as OEM applications.

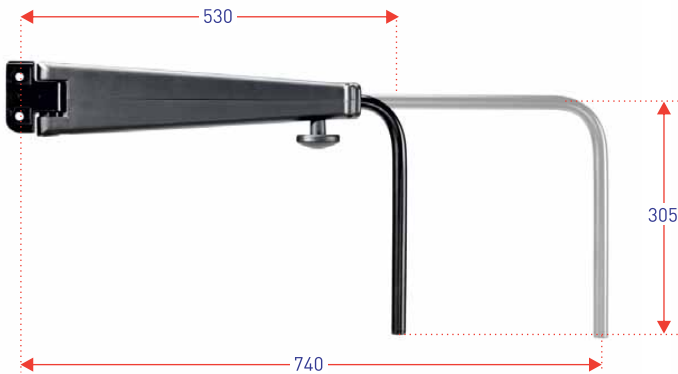

S2001

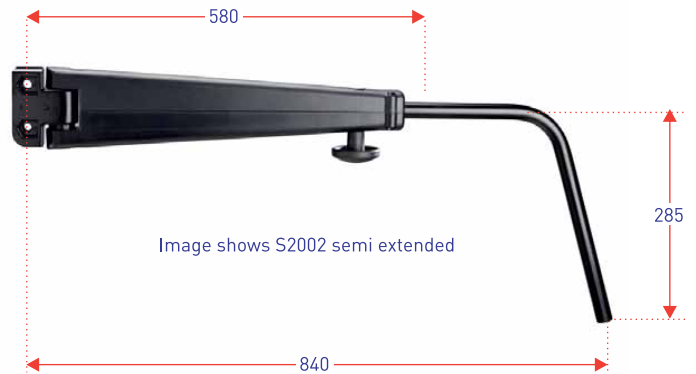

S2002

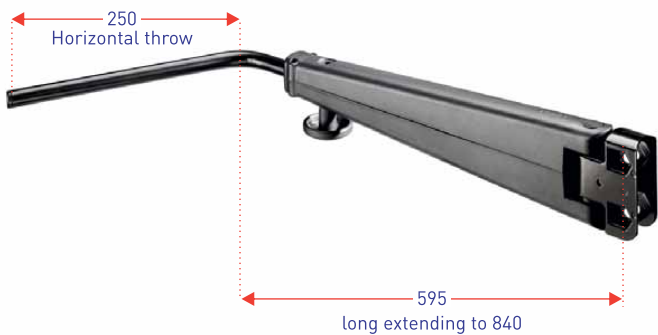

S2003L

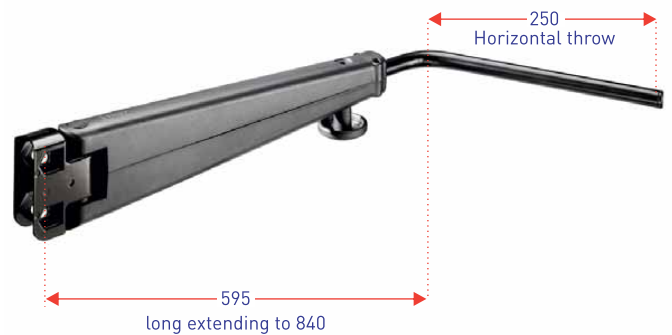

S2003R

Mirror Arms S1800



The S1800 range of arms are designed to be mounted onto a body mounted tab, ideal for when drilling holes isn't practical. Different styles give more options in positioning and also mirrors required to meet visibility requirements



S1801 & S1802



S1852



S1851

e11 III 03*6623



**M5000CE mirror
c/w S1801 mirror arms.**



M5000CE-S1801

Some concept ideas using the S1800 series mirror arms



The Pro-First range of beacons are Reg 10 & Reg 65 approved unless otherwise stated. They have been tried and tested across Europe for several years and have proved to be a great success.



AVS-BEA200

200 Series LED Beacon
Flexi DIN mount
12/24V
REG 10 & Reg 65 approved



AVS-BEA201

200 Series LED Beacon
1 Bolt mount
12/24V
REG 10 & Reg 65 approved

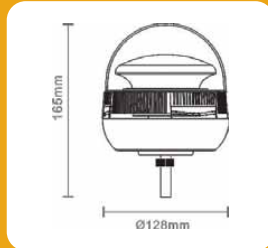

AVS-BEA202

200 Series LED Beacon
3 Bolt mount
12/24V
REG 10 & Reg 65 approved

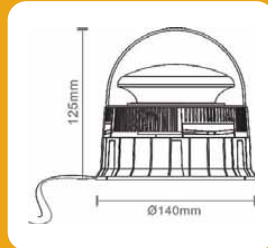

AVS-BEA203

200 Series LED Beacon
Magnetic mount
12/24V
REG 10 & Reg 65 approved

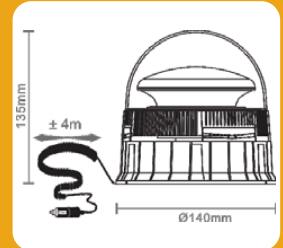

S900-DIN-Ver



S900-DIN-Hor

Designed for fitment on vertical or horizontal surfaces, these beacon mounts fasten on 2 x M6 threads at 60mm centres. They adjust at 20° increments and are ideal for preventing damage to beacons in transportation. They can be supplied with Ashtree AVS-BEA200, AVS-TMA300 or as a separate part

The Mighty Atom

The mini light with mighty performance

The TMA series is compact in size and offers a unique solution for restricted access mounting or where product vulnerability might be an issue. Whilst TMA may be small it delivers on lighting performance meeting the stringent ECE Reg 65 lighting regulation. This is achieved by using 18 x 1 watt LED emitters producing an outstanding warning light output.

Part numbers:

- AVS-TMA 200 - Magnetic
- AVS-TMA 100 - Flexi DIN
- AVS-TMA 300 - 3 bolt fixing

Specification:

- ECE Reg 65 approved
- Max Current; 1.7amp @12v, 0.85amp @24v
- IP 67 rated
- Reg 10 approved
- 18 LED 1Watt emitter
- Voltage 9-30v
- Multiple amber flash patterns including double, quad & quint flash

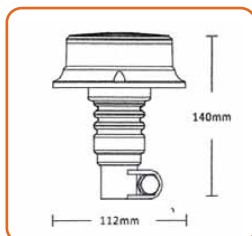
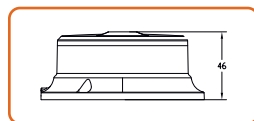

Seat Belts, Kits and Beacons

Fixed and flexible green seat belts, complete kits and a wide range of DIN connectors for all installations.



Fixed Kit - AVS-GBK1

- 1 x AVS BEA 200-GRN - Green Flex DIN beacon
- 1 x AVS SBLT100 Fixed connection seat belt
- 1 x AVS DIN102 Screw thread mount DIN connection



Flexi Kit - AVS-GBK2

- 1 x AVS BEA 200-GRN - Green Flex DIN beacon
- 1 x AVS SBLT105 Flexible connection seat belt
- 1 x AVS DIN102 Screw thread mount DIN connection

AVS-SBLT100

Seat belt fixed



AVS-SBLT105

Seat belt flexi



AVS-BEA200-GRN

200 Series LED Beacon
Flexi DIN mount
12/24v R10 Green

DIN Connectors

Ashtree DIN Connectors for use with Flexi Din Beacons



adaptor for green & amber beacons

AVS-DIN101

Stem fitted



AVS-DIN102

Threaded end



AVS-DIN103

2 point horizontal fitting



AVS-DIN104

2 point "L" bracket vertical fitting



AVS-DIN105

2 point 'U' bracket for vertical fitting



AVS-TPD100

Twin pin DIN connector for mounting 2 beacons. Ideal for when an amber and green beacon are required for site safety.

AVS-DIN106

2 point 'U' bracket for vertical fitting



AVS-DIN107

3 point circular bracket for horizontal fitting



AVS-DIN108

2 point fixing with folding bracket



AVS Reverse Alarms

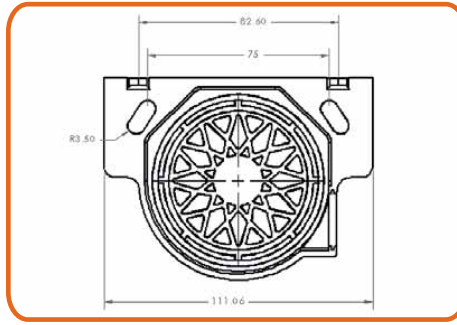

AVS ALARMS

Specification:

- Multi voltage 12-24v
- Comes with 300mm flying lead
- Reg 10 approved
- IP67 rated
- Fits industry standard mounting
- Beep Beep, Multi frequency or talking versions available
- Size w11 x h8 x d4.5cm

- AVS ALARM100** 12-100 Volt Reverse Alarm 97dBa
- AVS ALARM200** 12-24 Volt Reverse Alarm 97dBa Reverse twice
- AVS ALARM300** 12-24 Volt Multi-frequency Reverse Alarm 88dBa
- AVS ALARM400** 12-24 Volt Multi-frequency Reverse Alarm 88dBa Reverse twice
- AVS ALARM500** 12-24 Volt Multi-frequency Reverse Alarm 92dBa
- AVS ALARM600** 12-24 Volt Talking alarm "Warning this vehicle is reversing"

Accessories



AVS-SENSORSYS1

Parking distance system 4 sensors, screw fitting, 12/24v with display buzzer



AVS-BSALARM

Blind spot warning alarm only 12/24v with built-in indicator alarm with upgraded option



AVS-BSWLED

Blind spot warning alarm c/w amber led's 12/24v, built-in indicator alarm



AVS-PNP1

Plug 'n' play junction box including built in speed module and indicator module

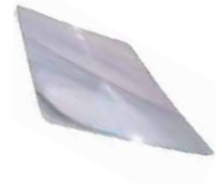

AVS-FRE20/25

Stick on Fresnel lens: 200 x 250mm angle 0~18 deg /side 0~28 deg

Smart LED Ballast Socket eliminates false alarms

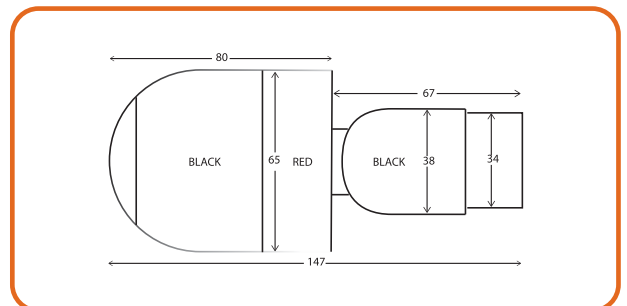

This clever towing socket mimics the load of traditional tail lights to eliminate false bulb failure warnings when using trailers equipped with LED lights.

The unit is of heavy duty construction with the electronics encapsulated in epoxy to protect against water and vibration.

Part number : AVS BAL 1

- Voltage 12 volts
- Eliminates bulb failure warning for trailers with LED lighting
- Mimics the load of normal lights
- Heavy duty construction
- Electronics epoxy encapsulated protecting against water & vibration
- Reg 10 approved

Worklamps & Lights



AVS-WLRE616

- L 160 x H 48 x D 61.5mm
- 6 x 3w LED emitters
- Cree LED
- 1620LM

AVS-WLRE690

- L 110 x H 62 x D 53mm
- 6 x 3w LED emitters
- Epistar LED
- 900LM

AVS-WLCU990

- L 50 x H 50
- 9 x 15w LED emitters
- 900LM

AVS-WLMB2

- Work light complete with clamp
- 9 x 3w LED emitters
- Clamp fits 16-28mm diameter pole

AVS-SCENE1

- 4 x 3w LED emitters
- IP67 rated
- 10-30 volt
- R10 approved
- 900LM

Standard specification: 10 - 30 volts • Stainless steel bracket • Die Cast aluminium housing
 • R10 CE approved • 6500K colour temperature • 1 year warranty

AVS-SLWLED4

High power slimline R65 approved LED light

Specifications:

- EMC reg10
- UN ECE R65 approved
- 4 x 3w LED emitters
- 4 Flash patterns
- Ultra-thin profile 13mm
- IP 67 rated
- Voltage 12-24v

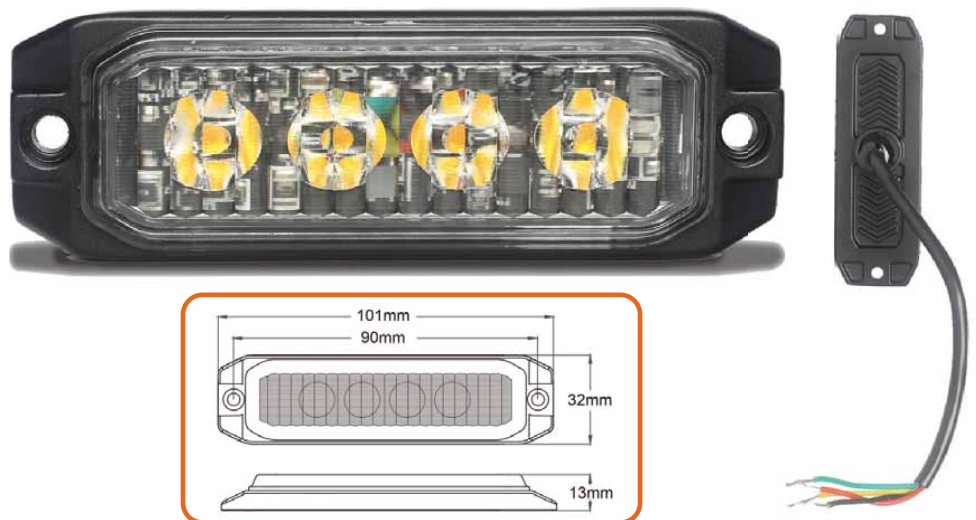

AVS-WTK1

- ECE: R7/R6
- EMC: R10
- IP65
- Progressive indicator signal/stop/tail & number plate illumination
- Rubber coated heavy duty magnets
- 12 volt only (Input voltage DC 2.5v)
- Wireless range 30 meters
- Rechargeable batteries supplied with USB adaptor & lead
- Charging time 2-2.5 hours
- 8 hour battery life in normal use
- Suitable for use for most agricultural applications (please consult vehicle owner's manual for compatibility with trailer lighting)

Wireless Trailer Kit



AVS-CAN1



CANBUS interface model required for certain car applications (sold separately).

Compact LED Mini Light Bars



R10 Approved

Part number:

AVS MLB200 - Mini lightbar, magnetic fitting, R10 approved with 8 flash patterns

Specification:

- 12-24v
- 8 Flash patterns
- Polycarbonate Lens
- REG 10 approved
- IP65
- 24 x 1watt LED's
- Extruded aluminium base
- Two fixings : Magnetic with plug & switch to change flash patterns
- 310mm L x 159mm W x 75mm H

IMPROVED DESIGN



R10 & R65 Approved

Part numbers:

AVS MLB500 - Mini lightbar, single bolt fitting, R10 & R65 approved with 26 flash patterns

AVS MLB600 - Mini lightbar, magnetic fitting, R10 & R65 approved with 26 flash patterns

Specification:

- 12-24v
- 26 Flash patterns
- Polycarbonate Lens
- REG 10 REG 65 approved
- IP65
- 30 x 1watt LED's
- Extruded polycarbonate base
- Two fixings : Magnetic with plug & switch to change flash patterns
- 280mm L x 165mm W x 57mm H



Used on Crop Sprayers

AVS-WLSQ4 Blue

- Blue LED Work Light
- 4 x 3w LED emitters
- 10-30 volt
- 1200LM
- Stainless steel bracket
- Die Cast aluminium housing
- R10 CE approved • 6500K colour temperature
- 1 year warranty

Indexing brackets for mounting beacons



AVS-ABM202

S1181-Y3135

The Ashtree **S1181-Y3135** is an indexing arm with a beacon mounting plate with European PCD.

The **AVS-ABM202** comes complete with the Ashtree **AVS-BEA202**.

Mirror Glass, Elements, Brackets and Accessories



After a few years of simply importing and distributing glasses Ashtree made a decision to open a dedicated glass cutting department in 1982. It's quite a grand title but at the time it was only one person who cut the glass using manual glass cutting equipment. It's all changed since then. We now have three automatic glass cutting machines as well as a semi automatic machine for cutting deep radius glass.

After the glass has been cut it is shatter proofed to European Union standards using the automated glass taping machine that we had specially built for the job.

The following pages show the standard range of glasses that we keep in stock. We can also cut glass to customers requirements, subject to minimum quantities.

G200CE	177 x 125	ASHTREE M2000CE / M200CE / M2000CEA2 / Universal 7 inch x 5 inch	Convex (1200r)
G200FE	177 x 125	ASHTREE M2000FE / M200FE / M2000FEA2 / Universal 7 inch x 5 inch	Flat
G209CE	203 x 130	ASHTREE M0209CE / Land Rover (new model) / Sherpa / Leyland DAF 200 / 400	Convex (1200r)
G2231CEHc	185 x 95	ASHTREE M922CEH / M922FEH / M923CEH / M923FEH	Convex (300r)
G223CEHc	185 x 95	ASHTREE M902CEH / M9021CEH / M902FEH / M903CEH / M9031CEH / M903FEH	Convex (400r)
GW232CE	174 X 129	ASHTREE M925CEH/M926CE wide angle mirror lens with backplate	Convex (300)
G2371CEHc	173 X 176	ASHTREE M920CEH / M9201CEH	Convex (300r)
G2381CE	174 X 174	ASHTREE M2381CE	Convex (300r)
G2382CE	174 X 174	ASHTREE M2382CE	Convex (200r)
G238CE	174 x 174	ASHTREE M238CE	Convex (400r)
G250CE	198 x 198	ASHTREE M250CE/M250CEB	Convex (300r)
G400CE	234 x 155	ASHTREE M400CE / DESMO 355	Convex (1200r)
G4101CE	236 x 152	ASHTREE M3101CE / M3101CEB / M4101CE	Convex (1800r)
G4102CE	236 x 152	ASHTREE M3102CE / M3102CEA1 / M4102CE	Convex (400r)
G410CE	236 x 152	ASHTREE M310CE / M310CEB / M310CEA1 / M410CE / M440CE / M440CEB / M440CEA2	Convex (1200r)
G410FE	236 x 152	ASHTREE M310FE / M310FEB / M310FEA1	Flat
G422CE	229 x 147	LDV Convoy (left hand)	Convex (1800r)
G423CE	230 x 150	LDV Convoy (right hand)	Convex (1800r)
G430CE	235 x 150	ASHTREE M430CE / M430CEB / M430CEA1 / M430CESW	Convex (300r)
GW433CE	236 x 172	ASHTREE M925CEH/M926CE large mirror lens with backplate	Convex (1200)
G435CE	210 x 112	ASHTREE M435CE / M435CEA2	Convex (300r)
G4402CE	236 x 151	ASHTREE M4402CE/M4402CEB	convex (450r)
G450CE	226 x 170	ASHTREE M450CE / M450CEB	Convex (1200)
G455CE	226 x 170	ASHTREE M455CE / M455CEB	Convex (300r)
G500CE	253 x 153	ASHTREE M5000CE / M500CE / Universal 10" x 6"	Convex (1800r)
G500FE	253 x 153	ASHTREE M5000FE / M500FE / Universal 10" x 6"	Flat
G504CE	250 x 150	ASHTREE M504CE / M504CEA / Scania	Convex (400r)
G508CE	253 x 151	Street sweepers / Renault Master / Traffic & 50	Convex (1800r)
G5201CE	291 x 170	ASHTREE M5201CE	Convex (1200r)
G520CE	291 x 170	ASHTREE M520CE / Mercedes / Duple	Convex (1800r)
G528CE	281 x 201	ASHTREE M528CE / John Deere	Convex (1800r)
G530CE	271 x 193	John Deere	Convex (1800r)
G5361CEHc	255 x 170	ASHTREE M9021CEH / M9031CEH / M9221CEH / M9231CEH	Convex (1200r)
G536CEHc	255 x 170	ASHTREE M902CEH / M903CEH / M922CEH / M923CEH	Convex (1800r)
G545CE	248 X 190	ASHTREE M545CE / M545CEB	Convex (1800r)
G555CE	255 X 175	ASHTREE M555CE / M555CEB / M555CEA2	Convex (1200r)
G600CE	300 x 210	ASHTREE M600CE / M600CES / M600CESW / Volvo / Scania	Convex (1800r)
G600FE	300 x 210	ASHTREE M600FE / M600FES	Flat
G601CE	337 x 193	ASHTREE M601CE / M601CES / Raydot CM500	Convex (1800r)
G602CE	331 x 214	ASHTREE M602CE / Bedford / Seddon Atkinson / Foden / ERF / Britax	Convex (1800r)
G6101CE	309 x 178	ASHTREE M6101CE	Convex (1200r)
G610CE	309 x 178	ASHTREE M610CE / MAN / VW	Convex (1800r)
G613CE	347 x 196	ASHTREE M613CE / M0613CE / M6013CE-BLACK / Iveco / Ford Eurocargo / Seddon Atkinson	Convex (1800r)
G624CE	300 x 214	Steyr / KHD	Convex (1800r)
G6261CE	315 x 225	ASHTREE M6261CE	Convex (1200r)
G626CE	315 x 225	ASHTREE M626CE / Case / McCormick / Massey Ferguson / New Holland	Convex (1800r)
G627CE	321 x 182	Valmet	Convex (1800r)
G629CE	304 x 218	Deutz	Convex (1800r)
G640CE	310 x 205	ASHTREE M640CE / M640CEB	Convex (1200)
G701CE	375 x 190	ASHTREE M701CE / Ford Cargo / Leyland / DAF / Foden / Volvo / Plaxton	Convex (1800r)
G702CE	356 x 170	ASHTREE M702CE / M0702CE / Mercedes / Duple	Convex (1800r)
G703CE	396 x 208	ASHTREE M703CE / ERF / AWD / Foden	Convex (1800r)
G7141CE	362 x 174	ASHTREE M7141CE	Convex (1200r)
G714CE	362 x 174	ASHTREE M714CE / Volvo / Magirus Deutz / MAN / Iveco	Convex (1800r)
G714CEHc	362 x 174	ASHTREE M912CEH	Convex (1800r)
G714FE	362 x 174	ASHTREE M714FE	Flat
G725CE	381 X 182	ASHTREE M725CEB	Convex (1200r)
G800CE	415 x 220	ASHTREE M800CE / Scania	Convex (1800r)
G801CE	407 x 184	ASHTREE M0801CE / Mercedes	Convex (1800r)
G802CE	430 x 193	ASHTREE M802CE / Volvo	Convex (1800r)
G811CE	405 x 190	Irizar coach	Convex (1800r)
GW815CEH	430x200	Scania 4 series main mirror lens with backplate	convex (1800)
G820CE	402 X 209	ASHTREE M820CE	Convex (1800r)
G8231CE	409 x 209	ASHTREE M8231CE	Convex (1200)
GW927CEH	370 x 173	ASHTREE M927CEH	Convex (1200)

Mirror Glass, Elements, Brackets and Accessories

G200CE 177 x 125
ASHTREE M2000CE / M200CE / M2000CEA2
 G200FE 177x 125
ASHTREE M2000FE / M200FE / M2000FEA2
 Universal 7 inch x 5 inch

G209CE 203 x 130
ASHTREE M0209CE
 Land Rover (new model)
 Sherpa / Leyland DAF 200 / 400

G2231CEHc 185 x 95
ASHTREE M922CEH / M922FEH / M923CEH / M923FEH

G223CEHc 185 x 95
ASHTREE M902CEH / M9021CEH / M902FEH / M903CEH / M9031CEH / M903FEH



GW232CE
ASHTREE M925CEH/M926CE WIDE ANGLE LENS

G2371CEHc 173 x 176
ASHTREE M920CEH / M9202CEH
 G2371CEHc 173 x 176
ASHTREE M920CEH / M9201CEH

G238CE 174 x 174
ASHTREE M238CE
 G2381CE 174 x 174
ASHTREE M2381CE

G250CE 198 x 198
ASHTREE M250CE / M250CEB

G400CE 234 x 155
ASHTREE M400CE / DESMO 355
 G4001CE 234 x 155
ASHTREE M4001CE / DESMO 365

G4101CE 236 x 152
ASHTREE M3101CE / M3101CEB / M4101CE
 G4102CE 236 x 152
ASHTREE M3102CE / M3102CEA1 / M4102CE
 G410CE 236 x 152
ASHTREE M310CE / M310CEB / M310CEA1 / M410CE / M440CE / M440CEB / M440CEA2
 G410FE 236 x 152
ASHTREE M310FE / M310FEB / M310FEA1

G422CE 229 x 147
 LDV Convoy (left hand)

G423CE 230 x 150
 LDV Convoy (right hand)

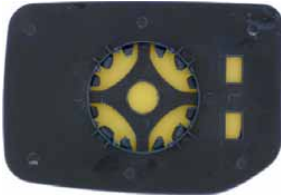

GW427CEL
 Transit LHS 2000 on



GW427CER
 Transit RHS 2000 on

G430CE 235 x 150
ASHTREE M430CE / M430CEB / M430CEA1 / M430CESW



GW433CE
ASHTREE M925CEH/M926CE MAIN LENS

G435CE 210 x 112
ASHTREE M435CE / M435CEA2

G4402CE 236 x 151
ASHTREE M4402CE / M4402CEB

G450CE 226 x 170
ASHTREE M450CE

G455CE 240 x 155
ASHTREE M455CE

G500CE 253 x 153
ASHTREE M5000CE / M500CE
 G500FE 253 x 153
ASHTREE M5000FE / M500FE

G504CE 250 x 150
ASHTREE M504CE / M504CEA
 Scania

G508CE 253 x 151
ASHTREE M0508CE / M0508CEA
 Street sweepers / Renault Master / Traffic & 50

G520CE 291 x 170
ASHTREE M520CE
 Mercedes / Duple
 G5201CE 291 x 170
ASHTREE M5201CE

G528CE 281 x 201
ASHTREE M528CE
 John Deere

G530CE 271 x 193
 John Deere

G5361CEHc 258 x 175
ASHTREE M9021CEH / M9031CEH / M9221CEH / M9231CEH
 G536CEHc 258 x 175
ASHTREE M902CEH / M903CEH / M922CEH / M923CEH

Mirror Glass, Elements, Brackets and Accessories

G545CE 248 x 190
ASHTREE M545CE / M545CEB

G555CE 255 x 175
ASHTREE M555CE / M555CEB /
M555CEA2

G600CE 300 x 210
ASHTREE M600CE / M600CES /
M600CESW
Volvo Scania
G600FE 300 x 210
ASHTREE M600FE / M600FES

G601CE 337 x 193
ASHTREE M601CE / M601CES
Raydot CM500

G602CE 331 x 214
ASHTREE M602CE
Bedford / Seddon Atkinson / Foden / ERF / Britax

G610CE 309 x 178
ASHTREE M610CE
MAN / VW
G6101CE 309 x 178
ASHTREE M6101CE

G613CE 347 x 196
ASHTREE M613CE / M613CE / M613CE-BLACK
Iveco / Ford Eurocargo / Seddon Atkinson

G624CE 300 x 214
Steyr / KHD

G626CE 315 x 225
ASHTREE M626CE
Case / McCormick / Massey Ferguson / New Holland
G6261CE 315 x 225
ASHTREE M6261CE

G627CE 321 x 182
Valmet

G629CE 304 x 218
Deutz

G640CE 310 x 205
ASHTREE M640CE

G701CE 375 x 190
ASHTREE M701CE
Ford Cargo / Leyland / Daf / Foden / Volvo / Plaxton

G702CE 356 x 170
ASHTREE M702CE / M702CE
Mercedes / Duple

G703CE 396 x 208
ASHTREE M703CE
ERF / AWD / Foden

G714CE 362 x 174 - ASHTREE M7141CE
G7141CEHc 362 x 174
ASHTREE M9121CEH / M9151CEH / M9161CEH / M920CEH /
M9201CEH / M9202CEH / M9203CEH
G714CE - ASHTREE M714CE
Volvo / Magirus Deutz / MAN / Iveco
G714CEHc
ASHTREE M912CEH / M915CEH / M916CEH / M920CEH
G714FE - ASHTREE M714FE
G714FEHc - ASHTREE M912FEH

G725CE 381 x 182
ASHTREE M725CEB

G800CE 415 x 220
ASHTREE M800CE
Scania

Mirror Glass, Elements, Brackets and Accessories



G801CE 407 x 184
ASHTREE M0801CE
Mercedes



G802CE 430 x 193
Ashtree M802CE
Volvo

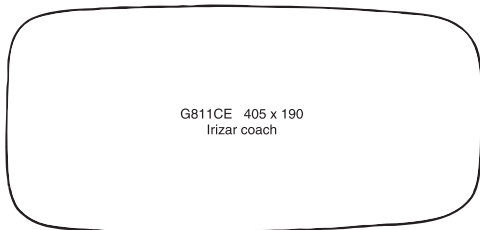

G811CE 405 x 190
Irizar coach



GW815CEH
SCANIA 4 SERIES MAIN MIRROR



G820CE 402 x 209
ASHTREE M820CE



G8231CE 409 x 209
- ASHTREE M8231CEB



GW927CEH
ASHTREE M927CEH



The Ashtree range of heating elements are designed to cover the largest possible range of heated mirrors currently in use. All elements are 24 volt but 12 volt versions are also available in certain sizes.

Y2610	318 x 175mm	24Volt
Y2611	173 x 137mm	24Volt
Y2611-12	173 x 137mm	12Volt
Y2613	160 x 160mm	24Volt
Y2614	208 x 173mm	24Volt
Y2615	385 x 165mm	24Volt
Y2616	410 x 190mm	24Volt
Y2618	310 x 130mm	24Volt
Y2618-12	310 x 130mm	12Volt
Y2619	250 x 145mm	24Volt
Y2619-12	250 x 145mm	12Volt
Y2621	145 x 70mm	24Volt
Y2621-12	145 x 70mm	12Volt

Mirror Glass, Elements, Brackets and Accessories

S1170 arm only
S1170X arm,
clamping piece
and M6 fixings

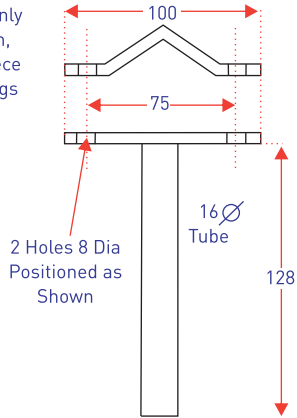

S1170 - S1170X

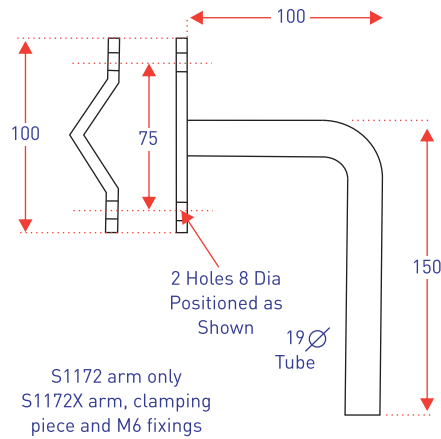

S1172 arm only
S1172X arm, clamping
piece and M6 fixings

S1172 - S1172X

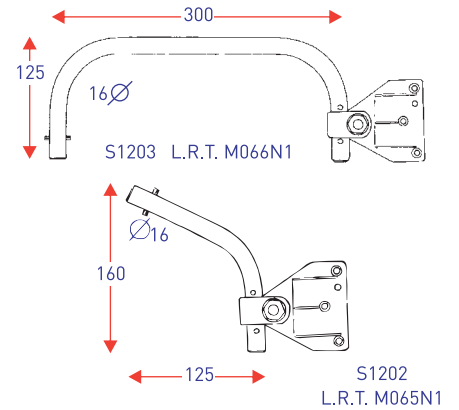

S1202 - S1203

MOUNTING 2 x 8mm HOLES @ 50mm crs

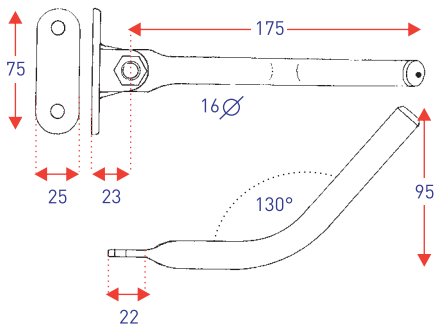

S1216

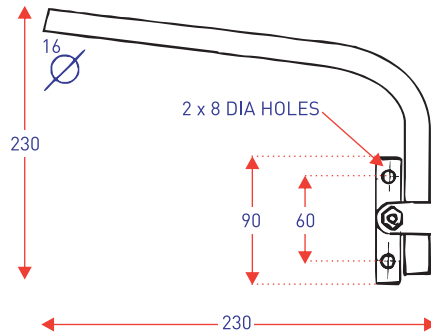

S1217



S1400 - S1412



S1403



S1406

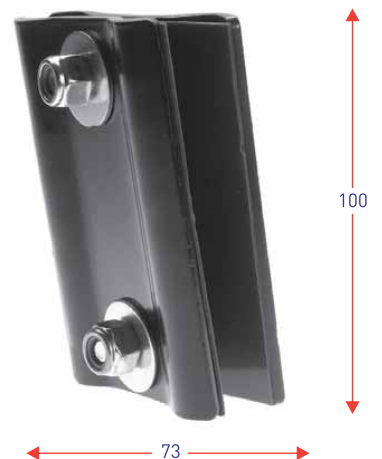

Y2680

Mirror Glass, Elements, Brackets and Accessories



PLH50

VTG6A heavyweight MOT plate holder

Body: black powder coated steel

Dimensions: 201mm x 184mm

Complete with clear plastic window



PLH52

VTG6A lightweight MOT plate holder

Body: rustproof glass filled nylon

Dimensions: 187mm x 180mm

Complete with clear plastic envelope



PLH60

Vehicle height indicator

Body: rustproof glass filled nylon

Dimensions: 187mm x 180mm

Changeable numerals from 8ft to 19ft 11".



PLH74S

Single pliable licence holder

Back & stem: zinc plated steel



PLH74D

Double pliable licence holder

Back & stem: zinc plated steel



PLH74T

Triple pliable licence holder

Back & stem: zinc plated steel

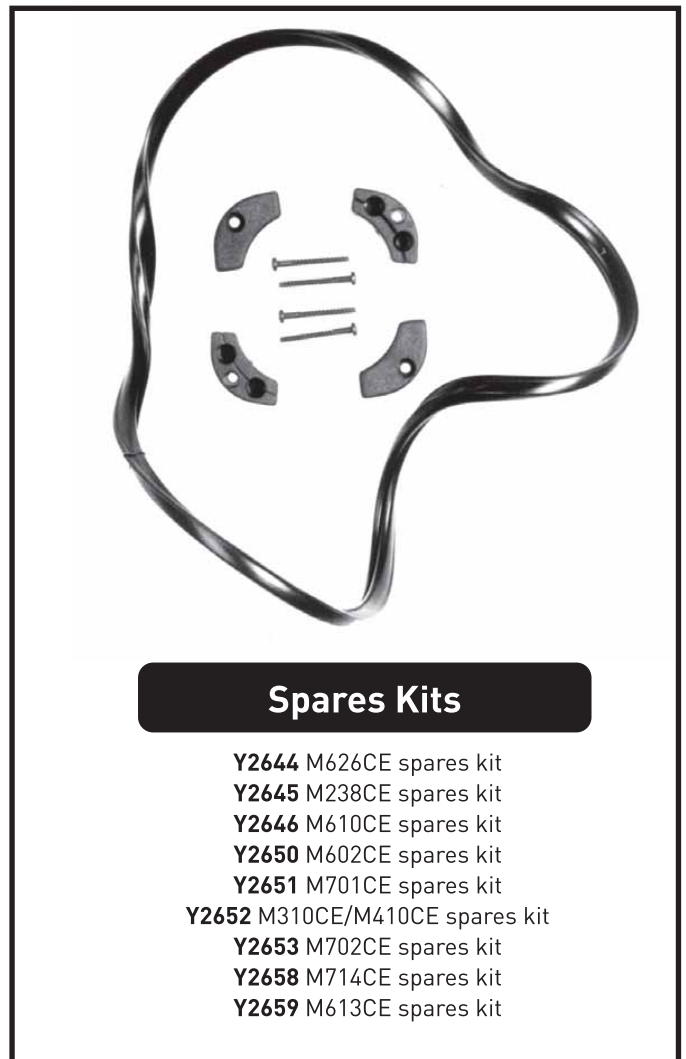

Spares Kits

- Y2644 M626CE spares kit
- Y2645 M238CE spares kit
- Y2646 M610CE spares kit
- Y2650 M602CE spares kit
- Y2651 M701CE spares kit
- Y2652 M310CE/M410CE spares kit
- Y2653 M702CE spares kit
- Y2658 M714CE spares kit
- Y2659 M613CE spares kit

Notes



A series of horizontal dotted lines spanning the width of the page, intended for taking notes.

Current EU regulations require that newly homologated vehicles are now fitted with mirrors which have been tested to the latest EU directives: 2003/97/EC & 2005/27/EC. For this reason most of our older mirrors are being re-tested and have the 03* prefix, instead of the old 02* prefix. Both numbers are shown in this list.

"e" Number	Ashtree Part No.	Page No.	"e" Number	Ashtree Part No.	Page No.
e11 III 02*1008	M400CE	11	e11 II 03*6626	M602CE	14
e11 II 02*3701	M600CE	14	e11 III 03*6627	M410CE	11
e11 II 02*3701	M600FE	14	e11 III 03*6628	M4101CE	11
e11 II 02*3701	M600CESW	14	e11 II 03*6630	M702CE	16
e11 IV 02*5465	M504CE	20	e11 I 03*6632	M310CEA1	31
e11 IV 02*5465	M504CEA	20	e11 I 03*6632	M310FEA1	31
e3 II 02*56323	MO613CE	15	e11 I 03*6633	M3102CEA1	31
e3 II 02*56323	MO613CE-Black	15	e11 IV 03*6633	M3102CE	19
E4 II 02*5914	MO225CE	10	e11 IV 03*6633	M3102CEB	19
e11 II 03*5957	M820CE	17	e11 III 03*6634	M3101CE	11
e11 II 03*6125	M626CE	15	e11 III 03*6634	M3101CEB	11
e11 III 03*6125	M6261CE	15	e11 III 03*6635	M310CE	10
e11 III 03*6126	M528CE	13	e11 III 03*6635	M310CEB	11
e11 II 03*6203	M915CEH	27	e11 III 03*6635	M310FE	11
e11 II 03*6203	M9151CEH	27	e11 III 03*6635	M310FEB	11
e11 II 03*6203	M916CEH	27	e11 00 03*6636	M520CE	13
e11 II 03*6287	M545CE	13	e11 00 03*6637	M5201CE	13
e11 II 03*6287	M545CEB	13	e11 II 03*6638	M613CE	14
e11 IV & V 03*6320	M238CE	19	e11 II 03*6639	M714CE	16
e11 IV & V 03*6320	M2381CE	19	e11 II 03*6639	M714FE	16
e11 IV & V 03*6343	MX6351CE	21	e11 II 03*6640	M7141CE	16
e11 IV & V 03*6343	MX6351CE	24	e11 II & IV 03*6641	M922CEH	27
e11 IV & V 03*6343	MX6351CE	36	e11 II & IV 03*6641	M923CEH	28
e11 VI 03*6343	MX635CE	21	e11 II & IV 03*6641	M9231CEH	28
e11 VI 03*6343	MX635CE	24	e11 II 03*6643	M610CE	14
e11 VI 03*6343	MX635CE	36	e11 III 03*6644	M6101CE	14
e11 IV 03*6404	M430CE	19	e11 II 03*6645	M912CEH	27
e11 IV 03*6404	M430CEB	19	e11 III 03*6737	M800CE	17
e11 IV 03*6404	M430CEA1	19	e11 III 03*6741	M807CE	17
e11 IV 03*6404	MX430CE	22	e11 IV & V 03*6843	M250CE	19
e11 IV 03*6404	MX430CEB	22	e11 IV & V 03*6843	M250CEB	19
e11 VI 03*6447	MX550CE	21	e11 IV & V 03*6843	MX250CE	22
e11 VI 03*6447	MX550CEB	21	e11 IV & V 03*6843	MX250CEB	22
e11 VI 03*6447	MX550CEA	21	e11 II & III 03*6921	M823CEH	17
e11 VI 03*6447	MX550CEA3	21	e11 IV & V 03*8012	MX4402CE	23
e11 VI 03*6447	MX550CE	23	e11 IV & V 03*8012	MX4402CEB	23
e11 VI 03*6447	MX550CEB	23	e11 IV & V 03*8012	M4402CE	20
e11 IV & V 03*6588	M435CE	20	e11 IV & V 03*8012	M4402CEB	20
e11 IV & V 03*6588	M435CE-Stud	20	E11 46R04/09*9211*00	M930CEH	29
e11 IV & V 03*6588	M435CE	31	E11 46R04/09*9211*00	M935CEH	29
e11 IV & V 03*6588	M435CE-Stud	31	E1 1 II, III & IV 048173	M925CEH	28
e11 IV & V 03*6588	M435CEA2	32	E1 1 II, III & IV 048173	M926CE	28
e11 II & III 03*6589	M725CEB	16	e11 VI 46R 048505	M5601CE	21
e11 II & III 03*6589	MX725CEB	25	e11 VI 46R 048505	M5601CEA	21
e11 II & III 03*6590	M555CE	13	e11 VI 46R 048505	MX5601CE	24
e11 II & III 03*6590	M555CEB	13	e11 VI 46R 048505	M5601CE	33
e11 II & III 03*6590	MX555CE	24	e11 VI 46R 048505	M5601CEA	33
e11 II & III 03*6590	MX555CEB	24	e11 VI 46R 048505	M5601CE	35
e11 II & III 03*6619	M440CE	11	e11 VI 46R 048505	M5601CEA	35
e11 II & III 03*6619	M440CEB	11	e11 VI 46R 048505	MX5601CE	36
e11 II & III 03*6619	MX440CE	23	IV 46R 048748	M455CE	20
e11 II & III 03*6619	MX440CEB	23	IV 46R 048748	M455CEB	20
e11 III 03*6622	M500FE	12	II 46R 048749	M450CE	12
e11 II 03*6623	M500CE	12	II 46R 048749	M450CEB	12
e11 II 03*6623	M5000CE	12	II 46R 048749	MX450CE	23
e11 II 03*6623	M5000FE	12	II 46R 048749	MX450CEB	23
e11 II 03*6623	M5000CEA4	12	e11 II 46R 048750	M640CEB	15
e11 III 03*6624	M2000CEA2	31	e11 II 46R 048750	MX640CEB	24
e11 III 03*6624	M2000FEA2	31	E11 49212	M703CE	16
e11 III 03*6624	M2000CE	10			
e11 III 03*6624	M2000FE	10			
e11 III 03*6624	M200CE	10			
e11 III 03*6624	M200FE	10			
e11 II 03*6625	M701CE	15			



are proud to supply:



BUS & COACH

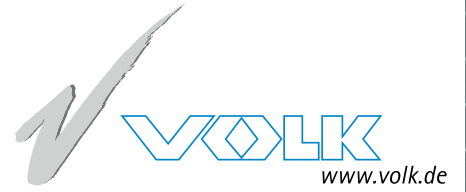

Ashtree would like to thank the customers above for permission to use their logos.

Ashtree Works, Brownroyd Street, Bradford, BD8 9AF, UK.

Tel: (0)1274 546732

Email: sales@avsuk.co

www.avsuk.co

© Ashtree Visions & Safety 2023



Certificate Number 21627



Certificate Number 21627

